



MULTIMASS

**MM600**

**MM900**

**MM1200**

**MM1500**

## User Manual

**Read carefully before use**

Dear user,

Thank you for placing your trust in us. We hope you will find your MX MULTIMASS satisfactory in every way.

This MULTIMASS user manual is a very important document, so please keep it for future reference as required. Make it available to any other users and hand it over to any new owner should your MX MULTIMASS be sold on.

The illustrations and technical data shown in this document may not correspond exactly to your MULTIMASS, although the operating requirements will nevertheless remain unchanged.



# CONTENTS

<b>1. SAFETY RULES</b>	<b>6</b>
1.1 Safety rules	6
1.2 Usage rules	6
1.3 Non-compliance with the safety and usage rules	7
<b>2. SAFETY STICKERS</b>	<b>8</b>
<b>3. DESCRIPTION OF MULTIMASS RANGE</b>	<b>9</b>
3.1 Multimass options	10
<b>4. PREPARING THE WEIGHT</b>	<b>11</b>
<b>5. 3-POINT AND AUTOMATIC HITCHING</b>	<b>12</b>
<b>6. ADDITIONAL WEIGHT MM400AD</b>	<b>13</b>
<b>7. MULTIBOX MBX:</b>	<b>16</b>
<b>8. PANEL KIT</b>	<b>18</b>
<b>9. COUNTERWEIGHT</b>	<b>21</b>
<b>10. TECHNICAL SPECIFICATIONS</b>	<b>22</b>



# 1. Safety rules

## 1.1 Safety rules

- Use a 3-point hitch for road use (safety) and when using the towing clevis.
- Once the MULTIMASS is hitched, check that the linkage's coupling yokes are locked.
- After using the tractor, place the weight on the ground.
- When unhitching the weight, ensure that the ground is flat and firm.
- When using the additional weight, ensure that when unhitching the primary + additional weight assembly, the assembly remains stable (refer to the "ADDITIONAL WEIGHT MM400AD" section).
- The width of the stops is designed for tractors with between-the-tyres width of at least 1,000 mm. Check that the tyres do not interfere with the stops.

**⚠ CAUTION:** Carry out a lifting test to check proper operation of the tractor/linkage/weight assembly (drawbar, ladder hitch, pick-up hook, grille, tyres, etc.).

## 1.2 Usage rules

**⚠ CAUTION:** there is a risk of the weight tipping when hitched in the lowest position (1).

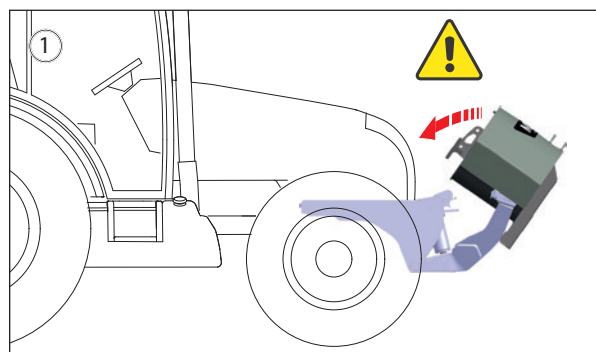

- Tool holders (2):
- Ensure that the tools (chainsaws, straps, pickaxes, etc.) are properly secured, to avoid any losses when underway.



Towing clevis (3):

- Maximum force in horizontal load is 3.5 tonnes and in vertical load is 1 tonne.
- The towing clevis is only intended for towing wheeled equipment.
- The towing clevis is not approved for use on public roads



- When towing, the pin (4) must be in the low position, to lock the tilt of the bracket.

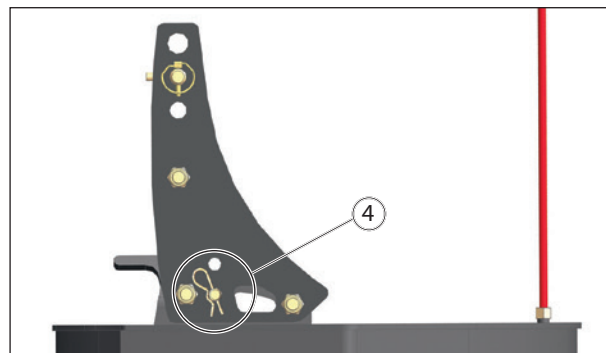





### 1.3 Non-compliance with the safety and usage rules

- Any modification to an MX supplied part shall invalidate the MX warranty on all its equipment.
- Use only genuine MX spare parts. Do not modify your MX equipment yourself, or have it modified by anyone else, without requesting prior written authorisation from MX. Failure to comply with these rules may render your MX equipment dangerous. In the event of damage or injury, MX shall not be held responsible in any way.
- Warranty cover will cease immediately in the event of failure to observe the standards and instructions for use and maintenance of the MX equipment, as stipulated in the user manual. MX shall not be held liable for any accident that might result from actions contrary to these restrictions.

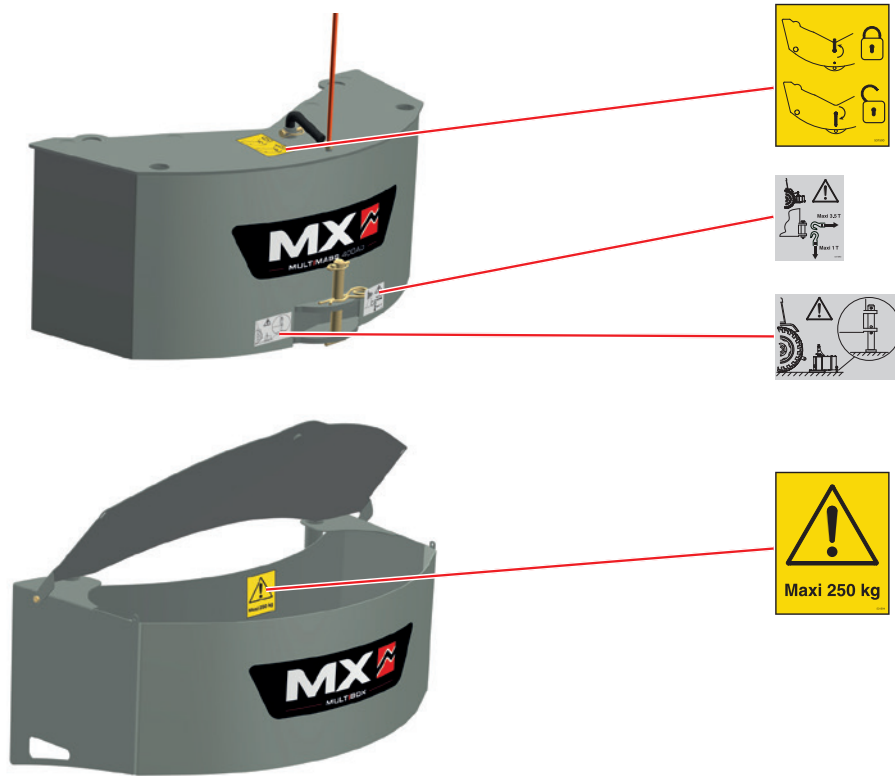
## 2. Safety stickers

Ensure that these stickers are clean and legible; replace them if they become damaged.

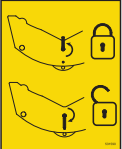



Sticker	Description
	Maximum horizontal tensile force 3.5 T. Maximum vertical tensile force 1 T.
	If removing the primary weight + additional weight, place the towing clevis pin in the stand position.
	Positions locked and unlocked of the MM400AD additional weight.
	Do not load more than 250 kg in the MULTIBOX

### 3. DESCRIPTION OF MULTIMASS RANGE

Weight	Model
 A grey cylindrical device with a black boot on top and a red vertical rod. The front has a black label with 'MX6' in white and red.	MM600 - MULTIMASS 600 kg
 A grey cylindrical device with a black boot on top and a red vertical rod. The front has a black label with 'MX9' in white and red.	MM900 - MULTIMASS 900 kg
 A grey cylindrical device with a black boot on top and a red vertical rod. The front has a black label with 'MX12' in white and red.	MM1200 - MULTIMASS 1200 kg
 A grey cylindrical device with a black boot on top and a red vertical rod. The front has a black label with 'MX15' in white and red.	MM1500 - MULTIMASS 1500 kg

### 3.1 Multimass options

\* optional equipment.

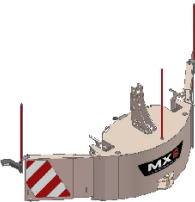
Option	Model
	MM400AD - Additional weight 400 kg *
	MBX - MULTIBOX *
	Panel kit *

## 4. PREPARING THE WEIGHT

- Fit the indicator rod using a 22 mm spanner.

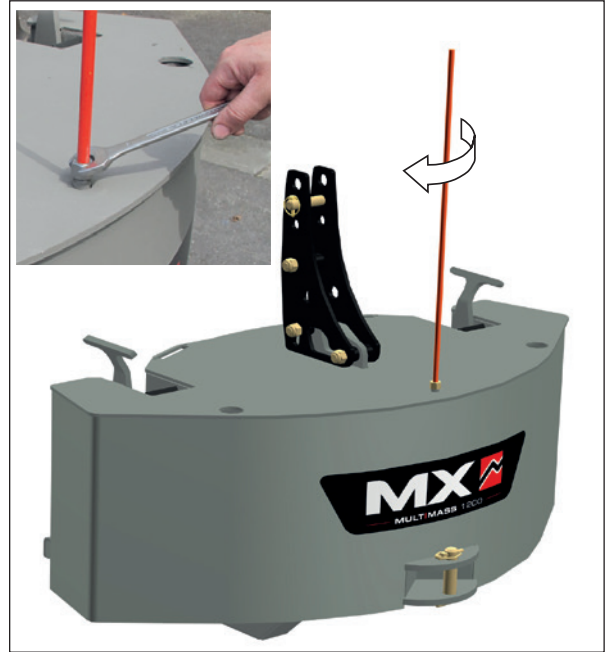

- Install the coupling balls.
- Adjust the height in accordance with the linkage.



If hitching to a Cat. 4 tractor,

- First unweld the guide plate in the base of the shoes

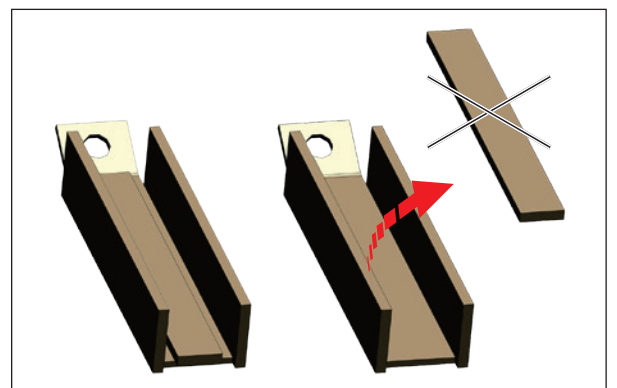

- Remove the shells and install the Cat. 4 ball joints and Ø 54 mm spacers (not supplied).

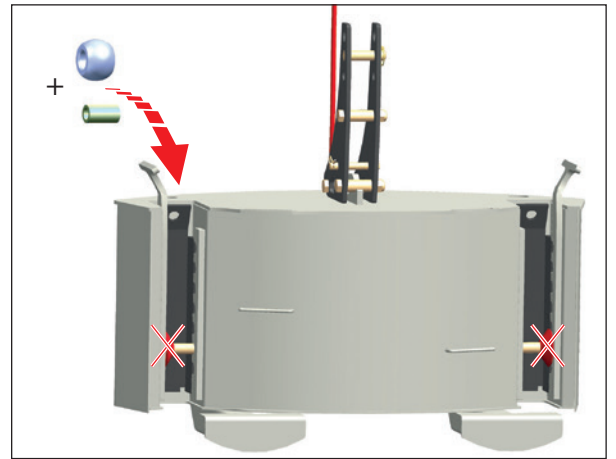

## 5. 3-POINT AND AUTOMATIC HITCHING

- Choose the 3-point or automatic hitch, according to use:
- short-term/frequent implement change = automatic (1).



- long-term/on-road/towing = 3-point (2).

**⚠ CAUTION:** Check that the pin (3) is correctly positioned.

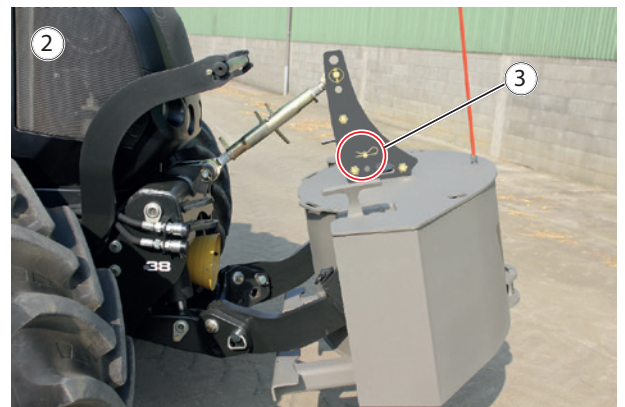

- When 3-point hitching is used, if the automatic support makes contact with the arms when lifting, the bracket tilts forward to ensure full compatibility (4).

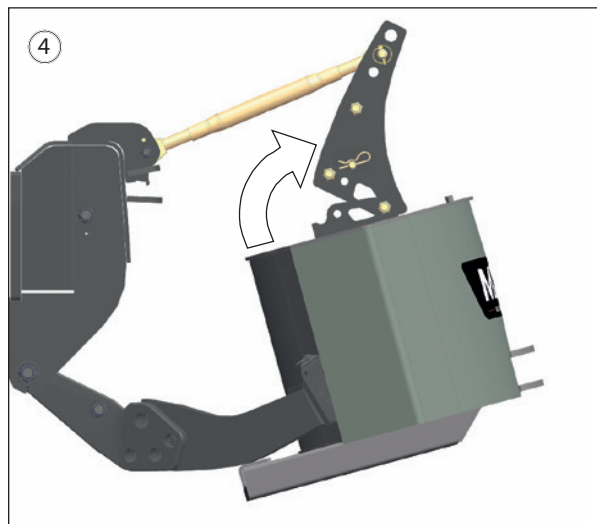

## 6. ADDITIONAL WEIGHT MM400AD

### 6.1.1 Hitching the additional weight MM400AD

- Move the primary weight towards the additional weight.

**⚠ CAUTION:** the pin must be on the primary weight (2).



- Connect the 2 weights.



- Lift the assembly.



- Lock the additional weight.

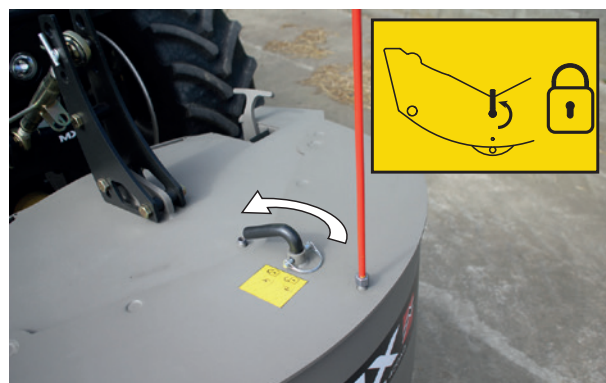

- Remove the parking supports from the additional weight.

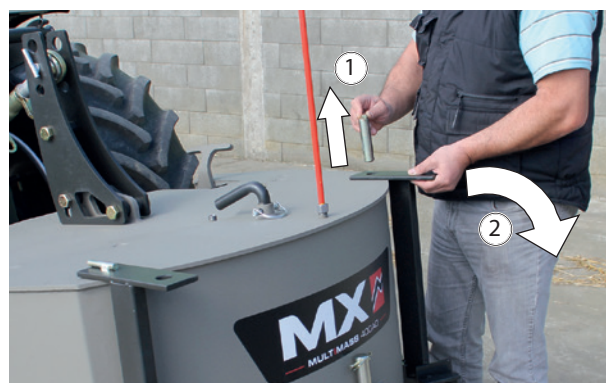

### 6.1.2 Unhitching the additional weight

Proceed as follows:

- Position the parking supports (1), (2), (3).
- Unlock the additional weight.
- Put the additional weight + parking support assembly on firm and level ground.

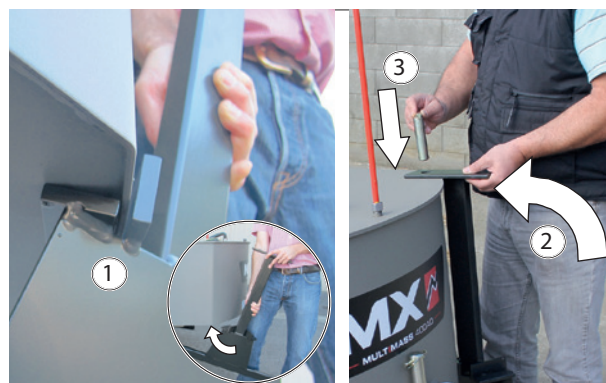

### 6.1.3 Unhitching the primary + additional weight assembly

**⚠ CAUTION:** When unhitching the primary + additional weight assembly, first place the towing clevis hitch pin in the stand position.

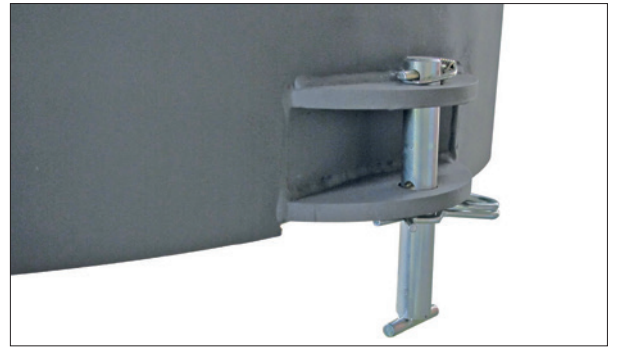

**NOTE:** The additional weight can be lifted by the locking handle.

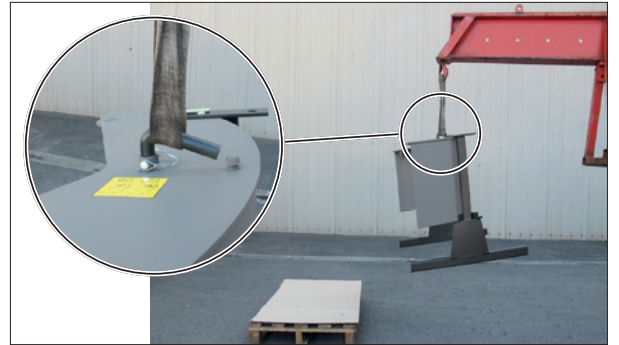

## 7. MULTIBOX MBX:

The MULTIBOX MBX is a storage box that can be fitted to the front of the weight (primary or additional).

- Capacity: 168 L.
- Depth: 38 cm.
- Height: 40 cm.
- Weight empty: 60 kg.
- Maximum load: 250 kg.

### 7.1.1 Hitching the MULTIBOX to the weight

- Remove the pin from the MULTIMASS (1).
- Unscrew the indicator rod using a 22 mm spanner (2).
- Use two people to place the MULTIBOX in position (3).
- Fit the MULTIBOX onto the MULTIMASS (4).

- Put the pin in position to lock the assembly (5).

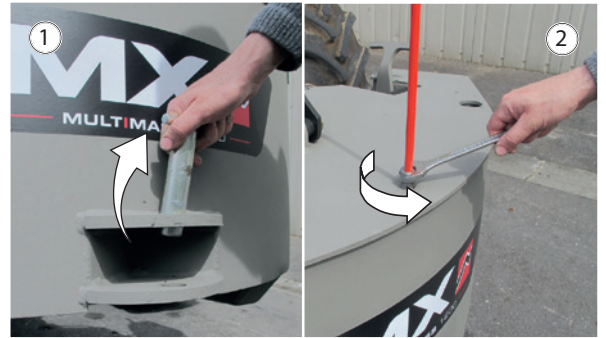

— Screw the indicator rod onto the MULTIBOX (6).

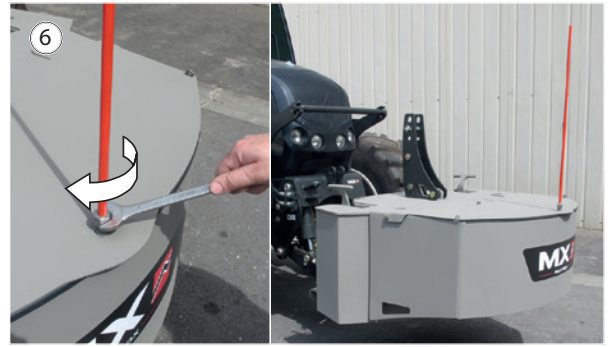

**⚠ CAUTION: Always place the weight + MULTIBOX assembly flat. The weight must be hitched at 3 points. Automatic hitching risks damaging the MULTIBOX (7).**



## 8. PANEL KIT

The panel kit (1) adds bumper functionality to a MULTIMASS.

**NOTE:** The PANEL KIT is compatible with the other MULTIMASS options (MULTIBOX, ADDITIONAL WEIGHT)

— This kit is available for prepared weights (2) (from April 2022).

— It is also available with fixing plates (3), for retrofitting on pre-2022 weights.



### 8.1.1 Panel adjustment

The MULTIBUMPER side panels are adjustable, without tools, according to the tractor's width:



- Remove the side panel clips and pins (1) (2)



- Slide the panel to the required length (3) and/or depth (4).
- Once the panel is adjusted, replace the clips and pins (1) (2) to secure it.
- Do the same for the other side panel.

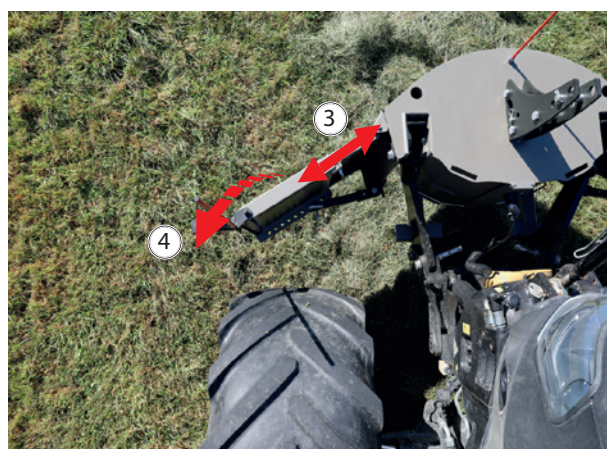

### 8.1.2 Panel kit electrical connection

The panel kit has a signalling option, with 6 LED position lights, to accentuate and highlight the moving tractor.

To connect the multibumper:

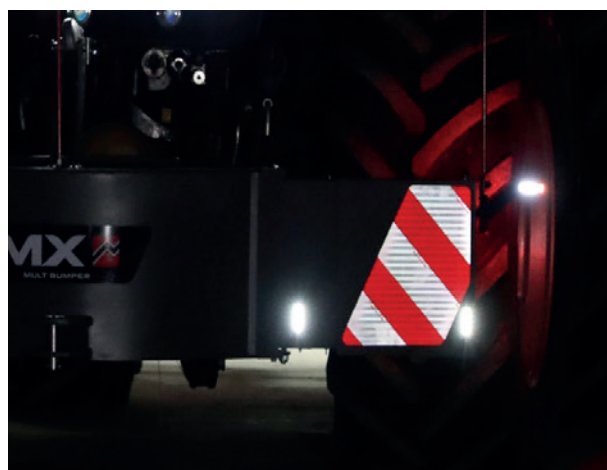

- Open the 7-pin socket and connect the extension cable to the tractor's electrical system.



### 8.1.3 Anti-vibration shear bolt

- The PANEL KIT is fitted with an anti-vibration bolt to prevent vibration and unwanted noise (1). The bolt must butt against the panel when adjusting.
- Each panel is also fitted with a shear bolt (2) for safety, and a spare bolt (3).

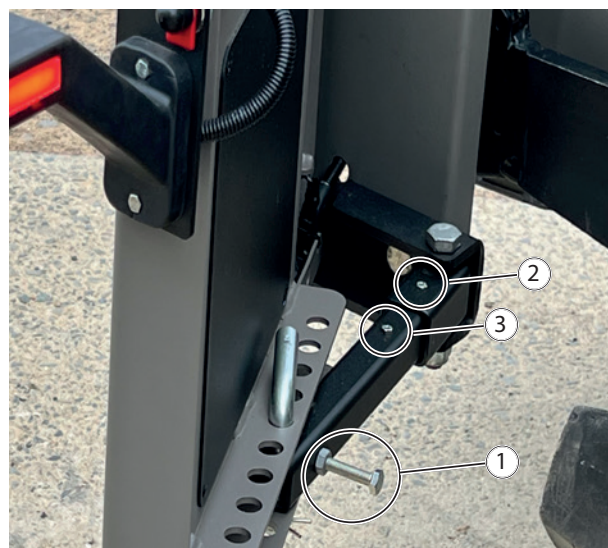

## 9. Counterweight

The stability of the tractor-loader unit can only be ensured with a counterweight installed on the rear of the tractor. This should ensure that 20% of the gross weight (tractor, loader, implement, maximum load and counterweight) bears on the rear axle of the tractor for optimum working safety.

The formula below is used to calculate the counterweight (M) (standard EN12525 + A2 2010).

- G: Load on the rear axle, with no counterweight, with empty implement (kg).
- G1: Load on the front axle, without counterweight, with empty implement (kg).
- b: Distance from front axle to the implement's centre of gravity (mm).
- l1: Distance from the linkage arm pin to the rear axle (mm).
- l2: Wheelbase (mm).
- N: Usable load of the loader for implement pivot point (A) horizontal with the loader pivot point (B) (kg).
- P: G + G1 (kg).
- M: Counterweight (kg).

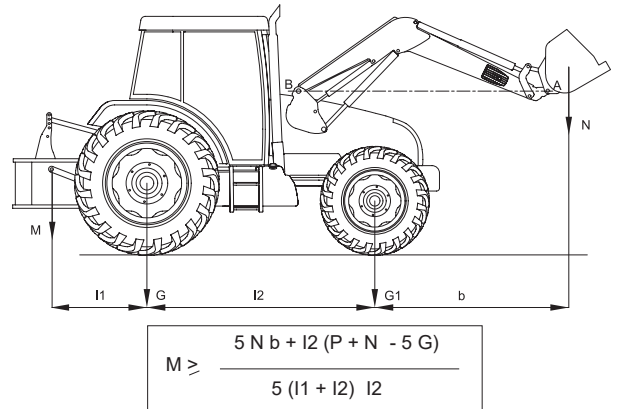

## 10. Technical specifications

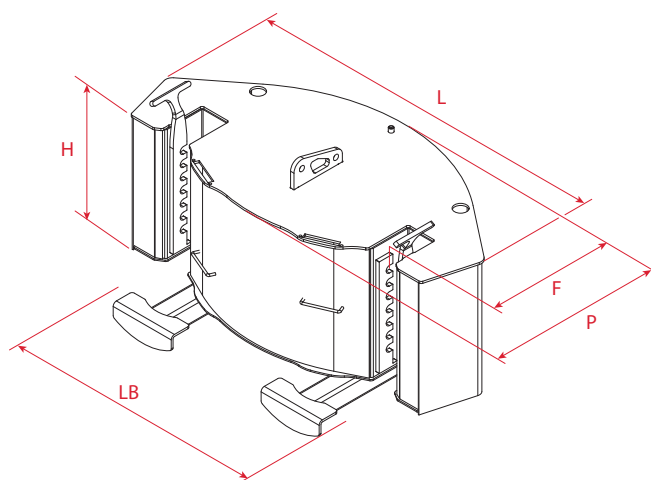

**NOTE:** The width of the stops is designed for tractors with between-the-tyres width of at least 1,000 mm. Check that the tyres do not interfere with the stops.

	MM600	MM900	MM1200	MM1500	MM400AD
Weight	600 kg	900 kg	1 200 kg	1 500 kg	400 kg
Width (L)	1 200 mm	1 200 mm	1 400 mm	1 400 mm	1 200 mm
Mini width between the tyres (LB)	1 000 mm	1 000 mm	1 000 mm	1 000 mm	1 000 mm
Height (H)	500 mm	500 mm	500 mm	500 mm	500 mm
Lenght (P)	585 mm	585 mm	675 mm	800 mm	+ 270 mm
Overhang (F)	385 mm	385 mm	475 mm	600 mm	+ 270 mm
Hitching type	3 pts and auto	3 pts and auto	3 pts and auto	3 pts and auto	
Hitching category	cat 2 to 4	cat 2 to 4	cat 2 to 4	cat 2 to 4	

# DECLARATION OF CONFORMITY



**The manufacturer:**

**M-extend France SAS**

Registered office: 19, Rue de Rennes, 35690 Acigné (France).

Registered with the RCS of Rennes under number 639 200 260.

**Hereby declares that the material :**

**Front loader** T408evo or T408+evo or T410evo or T410+evo or T412evo or T412+evo or T414evo or T417evo or T418evo or TX420evo or TX425evo or TX430evo

or

**Front loader** U503 or U504 or U505 or U506 or U506+ or U507 or U508 or U508+ or U509 or U510 or U510+ or U511 or U512 or U512+ or U514 or U514+

or

**Front loader** A104 or A106 or A110 or F303 or F304

or

**Front loader** C1 or C1s or C2u or C2 or C2+ or C3u or C3 or C3+ or C4 or C4+

or

**Loader implement** BMS or BRDS or BQU or BF + GF or CGU or TR or TRu or BMSC or CGC or TRC or BT or BR or BC or BF or BMSU or BRU or BFU or CL or BRC or BFC or LC or CG or BP or SG or BB or PCS or LS or PG

or

**Implement for telescopic handler loader** BMSA or CGA or BTA or TR or BCA or BCDA

or

**Feeding bucket** BD or GDT

or

**Manubal** L40 or L400 or L400HD or L500 or L6000 or C30 or C40 or U40 or V40 or V60 or V500 or W500 or V400HD or V5000HD or V7000HD

or

**Front linkage** R04 or R05 or R06 or R08 or R09 or R10 or R12 or R16 or R20 or R28 or R38 or R53

or

**Weight** M250 or M400 or MM600 or MM900 or MM1200 or MM1500 or MM400AD or MBX or MXS 250 or MXS 400 or MXS 600 or BOX 100L or BOX 150L or MBX XS

or

**Multibumper**

**serial number:**

please write in the box above the serial number given on the equipment's nameplate.

**included in the list of serial numbers 000001001 to 999999365,**

**is in conformity with the Machinery Directive 2006/42/EC  
and with the Supply of Machinery (Safety) Regulations 2008.**

M-extend France SAS, 19 rue de Rennes at Acigné (35690), is authorised to prepare the technical file.

Acigné, 2 September 2025.

**B. Gauchenot  
CEO**











M-extend France SAS  
19, rue de Rennes  
B.P. 83221  
FR-35690 ACIGNÉ  
Email : [contact@m-x.eu](mailto:contact@m-x.eu)  
Web : [www.m-x.eu](http://www.m-x.eu)