



RAISE YOUR EXPECTATIONS



LOADER

MX TX420

MX TX425

MX TX430

User Manual

Read carefully before using

Dear user,

We thank you for placing your trust in us and hope that you will find your MX loader satisfactory in every way.

By taking a few minutes to read this manual, you will be able to obtain the best results from your MX loader to the full, prolong its service life and ensure safe operation.

Your loader user manual is an important document. Keep it in a safe place along with the fitting instructions supplied by your dealer, so they can be consulted when necessary. Make it available to any other users and hand it over to any new owner should your MX loader be sold on.

The illustrations and technical data shown in this document might not exactly correspond to your loader, though operating conditions will nevertheless remain the same.

The loader should be handed over to the user by the dealer.

The demonstration of the equipment to be delivered should include:

- The safety instructions.
- Hitching and unhitching the loader.
- Hitching and unhitching the implements.
- Full use of the controls.

Should one of these 4 requirements be omitted, it is your responsibility to contact your dealership immediately.

You can access the original manuals in English on the www.m-x.eu website:

Select the English version of the site, then 'Documentation/User Manuals'.

MX is a trademark of M-extend France SAS, SIREN 639 200 260, RCS Rennes, 19 Rue de Rennes, BP 83 221 - 35 690 Acigné, France.

CONTENTS

1. SAFETY RULES	8
1.1 PPE Table (Personal Protective Equipment)	9
1.2 Loader operating limits on tractors without cab or 4-post rollbar	9
1.3 Non-compliance with the safety and usage rules	10
2. RULES OFD USE	11
3. SAFETY STICKERS	13
4. IDENTIFICATION PLATE	14
5. COUNTERWEIGHT	15
6. CONTROL	16
6.1 Control using the tractor's control valves	16
6.2 Control with MX e-PILOT S control valve	16
7. LOADER UNHITCHING	17
8. LOADER HITCHING	20
9. IMPLEMENT UNHITCHING	22
10. IMPLEMENT HITCHING	24
10.1 Lock the implement	24
11. MODELS OF IMPLEMENT CARRIER FRAMES	25
12. COMMISSIONING THE LOADER - CHECKLIST	27
13. LEVEL INDICATOR	28
14. SHOCK ELIMINATOR SYSTEM	29
15. AUTO-LEVEL SYSTEM	30
15.1 Implement position adjustment	30
15.2 Automatic implement position reset	31
16. AUTO-UNLOAD SYSTEM	31
17. SAFETY WHEN LIFTING AND DUMPING	32
17.1 Extract from the Front Loaders standard EN12525 + A2 2010:	32
17.2 Use of the lifting and dumping safety device	33
18. MAINTENANCE	34
18.1 Bracket maintenance specifications	36
18.2 Troubleshooting	37
19. RECYCLING MX PRODUCTS	41
20. TECHNICAL SPECIFICATIONS	43



**The loader is a complex machine.
The operator must read this manual
before using the loader for the first time.**



Familiarise yourself with:







- *The safety instructions.*
- *Hitching and unhitching the loader.*
- *Hitching and unhitching the implements.*
- *Full use of the controls.*

1. Safety rules

- PPE (Personal Protective Equipment) must be worn (see the "PPE table").
- Seat belts must be worn by the driver and passengers.
- Before each use, the operator must check that the loader is correctly hitched and that the implement is correctly locked (test by pressing hard to the ground).
- Only control the loader from the cab. Keep under control until movements stop.
- The loader controls must be locked when driving on the road (see the controls user manual).
- When approaching a junction, release the controls then raise the loader to at least 2 m above the ground to avoid endangering other road users. After passing the junction, return the loader to its initial position and lock the controls again.
- When driving on the road, do not mask the tractor's side lights and indicators.
- Do not leave the cab without stopping all control movements (control lever locked).
- Never leave the tractor with the loader lifted. After using the loader, park the tractor with the loader lowered to the ground.
- All persons must be kept away from the area in which the loader is moving while it is in operation. When lifting operations require the presence of a person near the load, the MX loader must be fitted with a safety device (see "LIFTING/DUMPING SAFETY").
- Before use, the operator should ensure that the loader-tractor unit and the implement-loader unit are compatible. They should refer to the MX price list in effect with their dealer.
- The operator must use an implement designed and recommended by MX for the work to be carried out.
- **Carrying or lifting persons using the loader is forbidden.**
- Ensure tractor stability by using a suitable counterweight (see "COUNTERWEIGHT").
- Restrict all movements with the load lifted as the tractor may become unbalanced.
- The maximum front axle loading, specified by the tractor manufacturer, must not be exceeded.
- In order to limit stresses on the front axle and steering ram, and to limit tyre wear, move forwards or backwards when steering.
- The maximum load on the front tyres, specified by the tyre manufacturer, must not be exceeded.
- Check tyre pressure regularly.
- Periodically check that the safety pins and bolts are in place. Do not replace them with any other items such as: nails, wire, etc.
- To ensure safe operation of the MX loader, the tractor must be equipped with a cab or a 4-post roll bar to protect against falling objects. Caution: the protection must be in the active position during operation. If the tractor is only equipped with a roll bar, the loader must be fitted with a parallelogram. Please refer to the chapter on "Loader use limits on tractors without cab or 4-post rollbar".
- Watch out for overhead electricity and telephone lines, guttering, framework, etc. when moving with the loader in raised position.
- In compliance with standard EN 12525 + A2 2010, the controls for operating the loader and implements must be of the "sustained action" type, except for the floating position for lifting and/or dumping, which can be held in place by a notching system.
- Any fault diagnosis and/or removal of parts must be carried out by a professional who is to start by ensuring that the work will be carried out safely, with minimal risk to themselves and their environment, especially in the case of work on a lifted loader.

- For all operations on the machine, the risks of crushing or pinching must be managed, especially with moving parts.
- For all work at height on the machine, use stable and secured means. Stop the tractor engine if the loader is hitched to the tractor.
- Keep the tractor-loader unit clean to avoid the risk of fire. Ensure that airborne particles (straw, grass, wood shavings, etc.) do not accumulate in areas which reach high temperatures. Inspect and clean areas where various materials can accumulate, especially around the engine and the exhaust area.
- After use, ensure that the tractor has been brought to a safe and secure stop.
- Never lift the loader and/or tool if the tool is obstructed/under stress.
- The maximum permitted working speed is 5 km/h.

1.1 PPE Table (Personal Protective Equipment)

Symbol	Meaning	Example of risk
	Hand protection equipment must be worn.	Cuts, trapped fingers when unlocking the implement on the loader.
	Ear protection must be worn.	Bucket shake with cab-less tractor.
	Eye protection must be worn.	Spatter when high-pressure cleaning.
	Helmet must be worn.	Impacts to the head with the loader during maintenance on the tractor.
	Body protection equipment must be worn.	Spatter when high-pressure cleaning.
	Foot protection must be worn.	Crushed feet when setting up the parking stands.

1.2 Loader operating limits on tractors without cab or 4-post rollbar

1.2.1 Warning

If the tractor is not equipped with a protective structure against falling objects (cab or 4-post rollbar), the operator is exposed to a permanent risk when handling a load.

NOTE: only implements recommended by the MX loader manufacturer may be used.

1.2.2 Safety precautions

For safe work, the following safety precautions must be observed:

- Use the implement designed for the work to be carried out.
- Adjust the indicator rod according to the implement used.
- Ensure the stability and hold of the load in the implement.
- The implement's maximum load level must not exceed the lowest wall for bulk loads and not exceed the backplate's height for unit loads (see Fig. 1).
- Move the tractor-loader unit carefully.
- Travel with the load at ground level and at moderate speed.
- During a lifting operation and when moving, keep your eyes on the load from when the implement's pivot point (A) passes the horizontal of the loader's pivot point (B) (see Fig. 2). If necessary, correct the implement's position so that the load is never directed towards the driver (see Fig. 3).

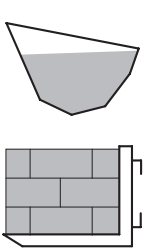

Fig. 1

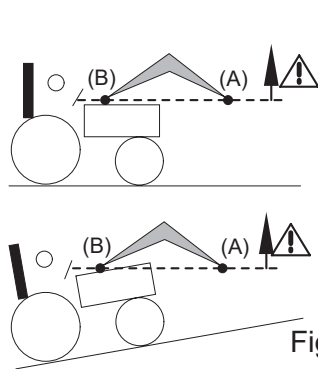

Fig. 2

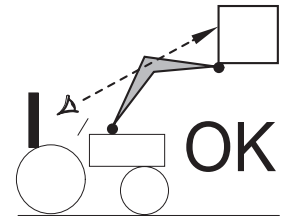
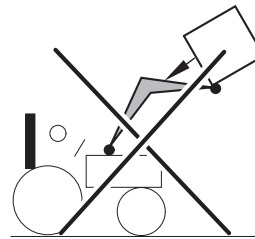

Fig. 3

! DANGER: If the load is not properly secured, there is a risk of the load falling when the implement pivot point (A) exceeds the horizontal of the loader pivot point (B) (see Fig. 2).

DANGER: It is prohibited to crowd the loader when the implement pivot point (A) exceeds the horizontal of the loader pivot point (B) (see Fig. 2).

1.3 Non-compliance with the safety and usage rules

- MX products are designed to be used at the maximum hydraulic pressure indicated by the manufacturer for the tractor's specifications. Use of excess pressure will result in additional strain and will therefore invalidate the MX equipment warranty.
- Never make any changes to the hose connections.
- Breaking lead seals will void any liability on the part of MX for all its equipment.
- Any assembly of the MX loader which ignores the recommendations of the MX price list in force at the purchase date cancels the MX guarantee for the whole supply.
- Any modification to any item supplied by MX (implements, loader, frame, etc.), or installation or use of an implement or component not recommended by MX on the MX loader, will render the MX guarantee on all supplied items null and void.
- Only original MX spare parts should be used. Do not carry out any modifications yourself or have anyone else do so on your MX loader and its implements (mechanical, electrical, hydraulic or pneumatic specifications) without seeking prior approval in writing from MX. Failure to comply with these rules may make your MX loader hazardous. In the event of damage or injury, MX shall not be held responsible in any way.
- Warranty cover will cease immediately in the event of failure to observe the standards and instructions for use and maintenance of the MX loader as stipulated in the user manual. MX shall not be held responsible for accidents that might result from actions contrary to these restrictions.

2. Rules of use

- Each implement has been designed for a specific use and has its own resistance limits.
- Land clearing and stump pulling are prohibited. This work must be done with specialized machinery and is not appropriate for the agricultural loader.
- Use the tractor's driving power to penetrate into the material to be moved rather than speed, which subjects the loader and tractor to high stresses.
- When the load to be moved is too big, do not force on the hydraulic components. The same applies when the rams are fully extended. Release the control valve levers.
- Always work with a centred load.

- For ground levelling, work at slow speed with an implement-to-ground angle of 50° at most.

NOTE: Work flexibly and carefully.

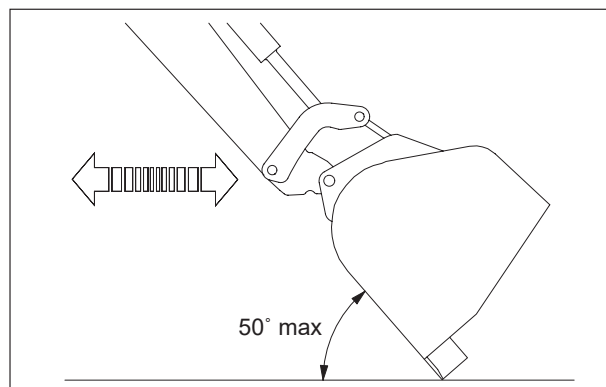

- When handling bales, check that the bale is held correctly before lifting the loader.

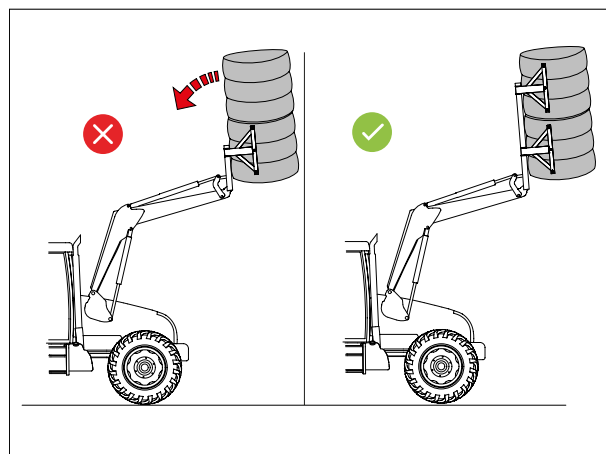

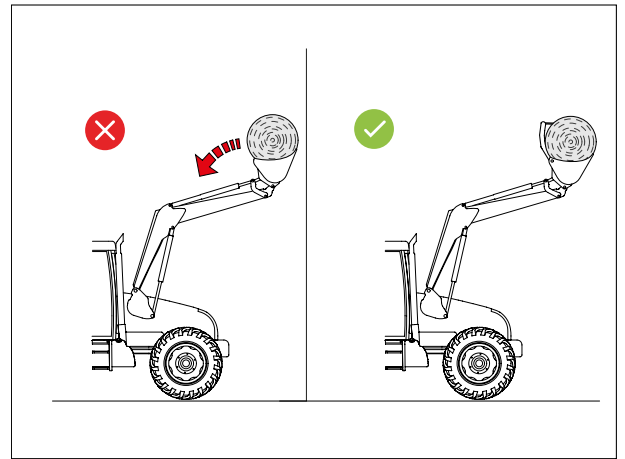

— Use the implement designed for the work to be carried out.

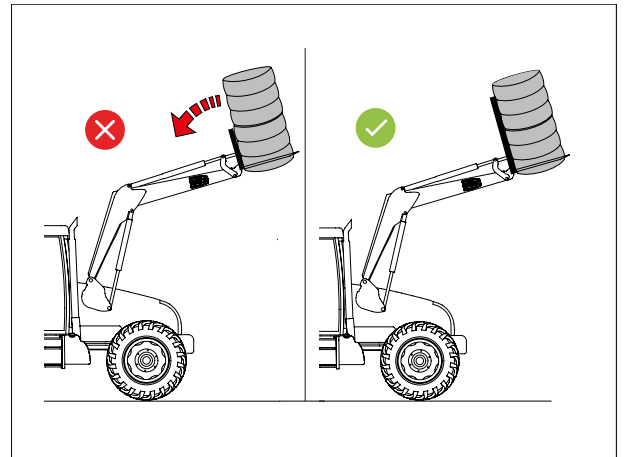

— The implement's maximum load level must not exceed the lowest wall for bulk loads and not exceed the backplate's height for single unit loads.

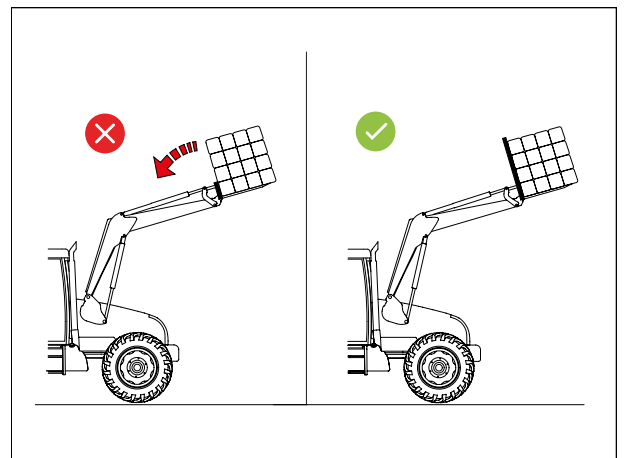

Unit load

3. Safety stickers

Safety stickers are affixed to loaders. Ensure that these stickers are clean and legible; replace them if they become damaged.

If replacing a sticker, clean the surface with isopropyl alcohol and stick on the sticker using a special tool.

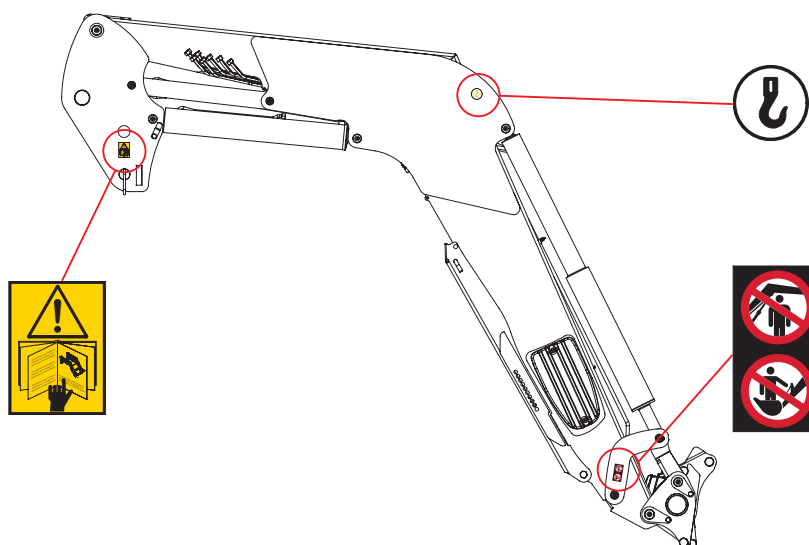

Familiarise yourself with the safety instructions in the user manual before using or working on the loader. Follow the loader hitching and unhitching procedure given in the user manual.



Use the anchoring points when handling the loader.



Handling above people is prohibited. Use of the loader and implements for purposes other than the material handling for which they were designed is prohibited.

4. Identification plate

The identification plate is located inside the loader's right arm. The serial number and loader model shown on this plate must be quoted in any request for spare parts information or technical assistance.

MX	CE	UK	CA
Designation	<input type="text"/>		
Type/Model	<input type="text"/>		
Serial number	<input type="text"/>		
Year of manufacture	<input type="text"/>		
Maximum weight	<input type="text"/>	kg	
For Loader: Maximum Load (on pallet carrier)	<input type="text"/>	kg	
Manufactured by M-extend france SAS 19 rue de rennes 35690 ACIGNE - FRANCE			



MAXIMUM LOAD (on pallet carrier)

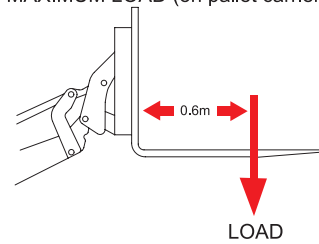

5. Counterweight

The stability of the tractor-loader unit can only be ensured with a counterweight installed on the rear of the tractor. This should ensure that 20% of the gross weight (tractor, loader, implement, maximum load and counterweight) bears on the rear axle of the tractor for optimum working safety.

The formula below is used to calculate the counterweight (M) (standard EN12525 + A2 2010).

- G: Load on the rear axle, with no counterweight, with empty implement (kg).
- G1: Load on the front axle, with no counterweight, with empty implement (kg).
- b: Distance from front axle to the implement's centre of gravity (mm).
- l1: Distance from the linkage arm pin to the rear axle (mm).
- l2: Wheelbase (mm).
- N: Usable load of the loader for implement pivot point (A) horizontal with the loader pivot point (B) (kg).
- P: G + G1 (kg).
- M: Counterweight (kg).

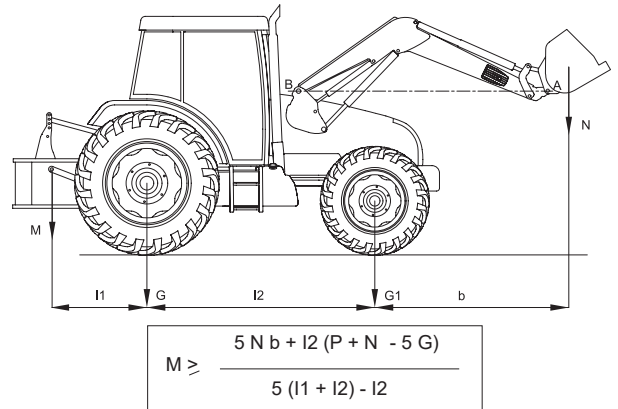

6. Control

! **Reminder: Never leave the tractor with the loader lifted.**

Every control valve with spool generates an internal leak required for proper operation.

6.1 Control using the tractor's control valves

Refer to the user manual for the tractor.

6.1.1 Front/rear control selector (optional)

From the tractor's original joystick, the user in the cab controls either the MX loader or the rear couplings.

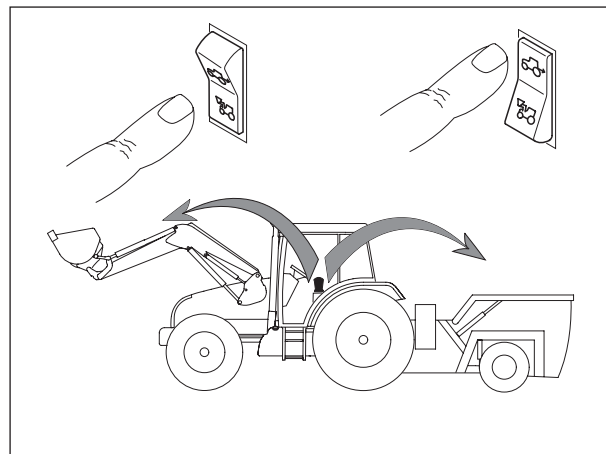

6.2 Control with MX e-PILOT S control valve

See manual specific to e-PILOT S.

7. Loader unhitching

! This operation must be carried out by the driver, who must exit the cab and ensure all manoeuvres are prohibited while working on the loader.
Watch the unhitching/hitching video at www.m-x.eu

The loader must always be connected to an implement of at least 100 kg in order to unhitch it.

— Choose a level and solid surface.



— Lower the left and right parking stands.



- Remove the locking pins from the frame and put them in the available holes.

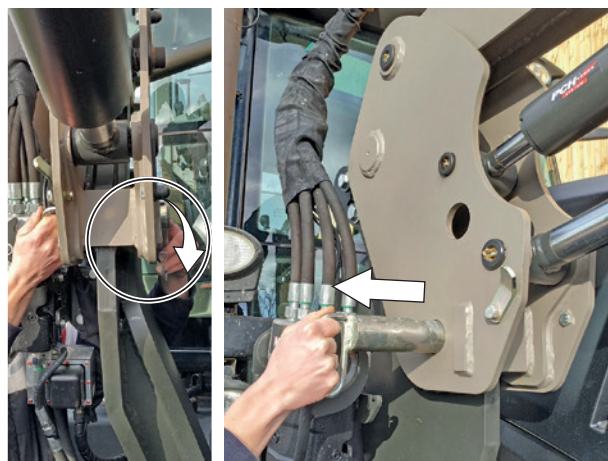

- Lower in double action to retract the lifting rams.
- Position the implement on the ground, slightly dumped (approx. 20°).
- Crowd slightly to set down the parking stands.



- Crowd slightly by moving forwards to release the bracket frames.
- Apply the hand brake. Stop the engine.

NOTE : if the the tractor has an original control valve system with Mach System 7 couplings, decompress the 3rd function hydraulic circuit as well.



- Disconnect the hydraulics and the electrics. Loader with MACH System:
 - Unlock the housing of the MACH System by pressing the safety latch on the left, then lift the handle.



- Hook the MACH System housing onto its support.

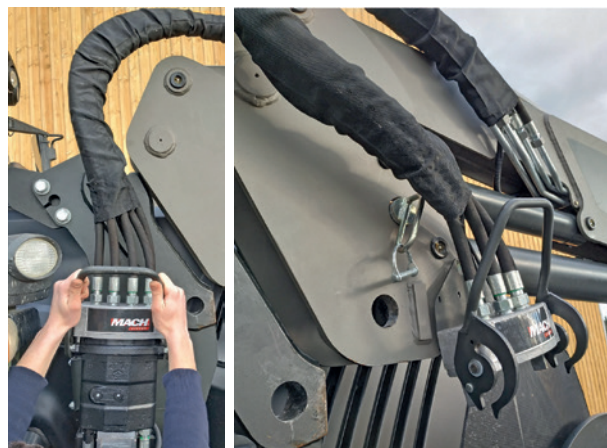

- Reverse the tractor in one motion, then slowly until the loader is resting on its parking stands.



- Check the stability of the whole assembly.



8. Loader hitching

! This operation must be carried out by the driver, who must exit the cab and ensure all manoeuvres are prohibited while working on the loader.
 Watch the unhitching/hitching video at www.m-x.eu

- Advance the tractor slowly so that the bracket is approx. 5 cm behind the frames.
- Apply the hand brake.
- Stop the engine.



- Connect the hydraulics and the electrics. Loader with MACH System:
 - Ensure that the male and female couplings are clean before connection. If necessary, clean them.
 - Take the housing with two hands and with its back, lift the control valve cover then engage the guide bars vertically.

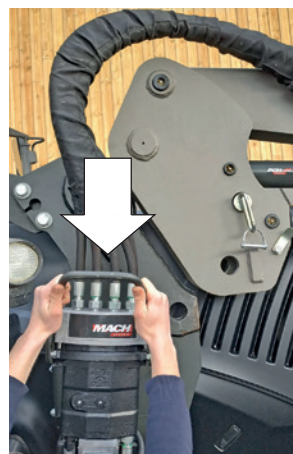

Dump the implement to lift the front of the loader:
— By pivoting, the frames fit into the bracket yokes.



— Lift the loader 0.5 m above the ground.



— Lock the loader frame onto the bracket with the spindles.



— Fold away the parking stands.



9. Implement unhitching

! This operation must be carried out by the driver, who must exit the cab and ensure all manoeuvres are prohibited while working on the loader.

- Choose a level and solid surface.
- Position the implement horizontally, 0.30 m above the ground.
- Engage the hand brake.

NOTE : If the loader has a solenoid valve, switch on the ignition and press the control button.



Implement unlocking

Control: button (4) pressed, the joystick vibrates. The LED flashes orange.

Depending on the model of e-PILOT S:

- Hold button (4) and GREEN button (2) combined with joystick to the right.
or
- Hold button (4) and GREEN thumbwheel (3) upwards.

NOTE : if tractor is controlled using original control valves, actuate the Fast-Lock with the dedicated control to unlock the implement.

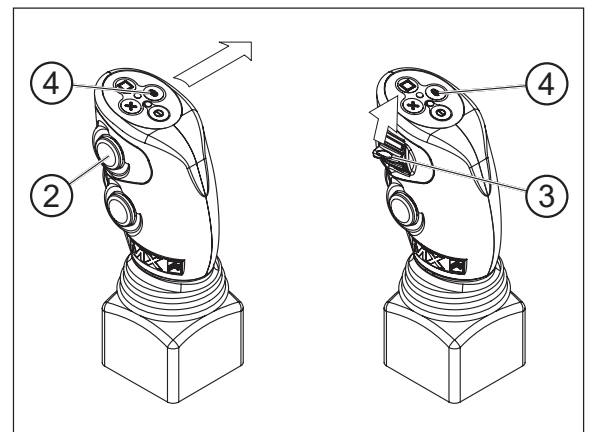

If the implement has hydraulic functions:

- Depressurize the hydraulic system.
- Disconnect the Mach 2 box.



- Put the hoses on the front of the implement.

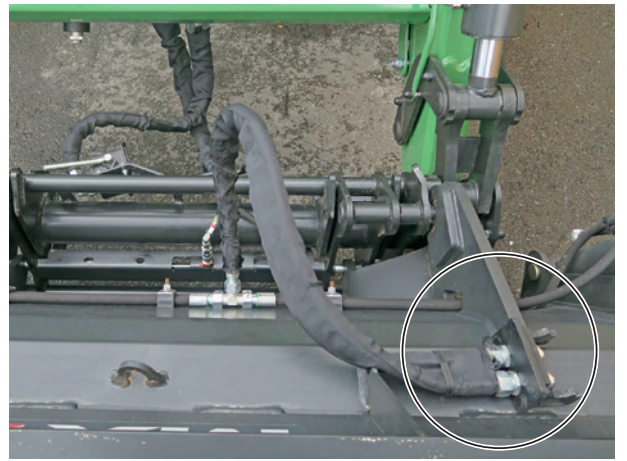

- Set the implement down on the ground by lightly dumping to release the implement carrier from the implement.

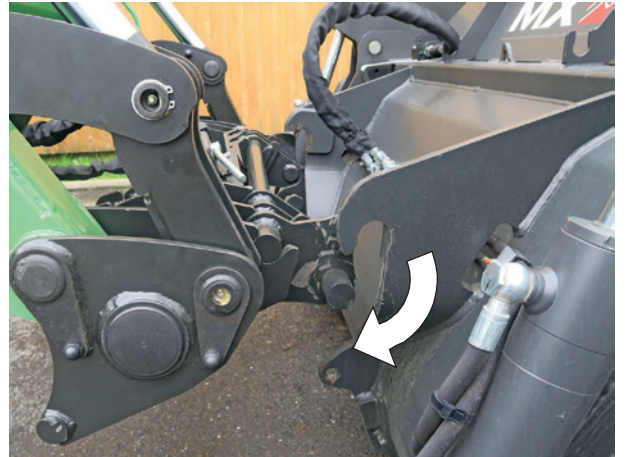

10. Implement hitching

! This operation must be carried out by the driver, who must exit the cab and ensure all manoeuvres are prohibited while working on the loader.

- Align the loader with the implement.
- Before attaching the implement, make sure that the locks are in the "open" (1) position to allow space for the implement parts.

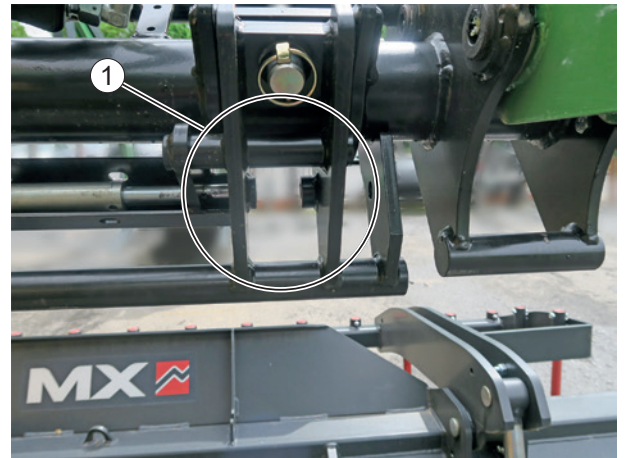

- Align the loader with the implement,
- Fit the implement carrier onto the implement,
- Crowd slightly and raise the loader to lift the implement from the ground.

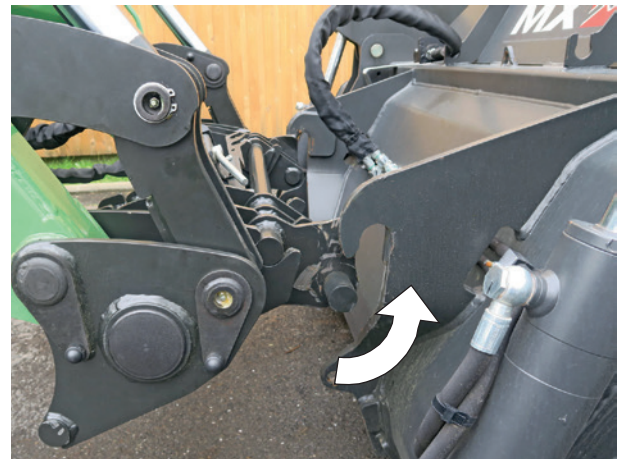

10.1 Lock the implement

Control: button (4) pressed, the joystick vibrates. The LED flashes orange.

Depending on the model of e-PILOT S:

- Hold button (4) and GREEN button (2) combined with joystick to the left.
- or
- Hold button (4) and GREEN thumbwheel (3) down.

NOTE : If tractor is controlled using original control valves, actuate the Fast-Lock with the dedicated control to lock the implement.

NOTE : If the implement has hydraulic functions, decompress the hydraulic circuit before connecting the Mach 2 box.

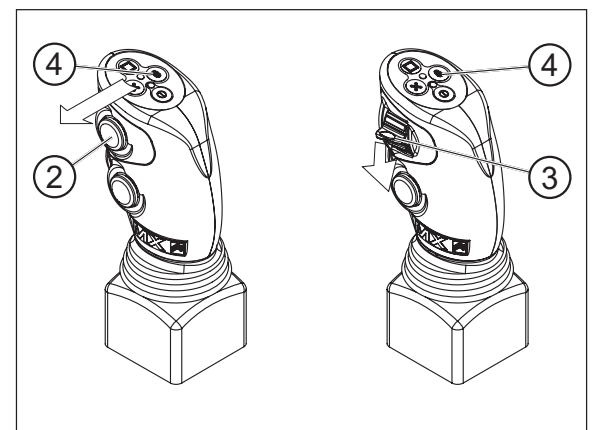

! Checks to be carried out before moving:

Press the implement down on the ground (the tractor's front wheels lift) to check correct locking.

Operate each moving part fully, in each direction, to check the integrity of the hydraulic circuit and the correct routing of the hoses.

11. Models of implement carrier frames

— MX implement carrier



— Euro implement carrier



— Claas Kramer implement carrier



— Manitou implement carrier



— JCB Q-Fit implement carrier



12. Commissioning the loader - checklist

Once the loader is hitched, carefully check all the functions before use. Go through all the necessary corrective steps in the event of a malfunction.

- Check that the loader is correctly hitched to the tractor (see “LOADER HITCHING”).
- Check the stability of the loader-tractor unit (see “COUNTERWEIGHT”).
- Check the condition of the fasteners. Replace, clean and re-tighten if necessary (see “MAINTENANCE”).
- Check that there is no interference between the loader and the tractor. Make sure that the wheels do not touch the loader at full steering angle. Adjust the spacing or limit the turning angle if necessary.
- Check that the indicator rod is operating correctly.
- Ensure that all maintenance operations are carried out correctly and in accordance with the maintenance schedule (see “MAINTENANCE”).
- Test all loader functions at both maximum load and low speed to check that the hydraulic circuit is properly sealed and that the hoses are correctly positioned (see “MAINTENANCE”).
- Bleed air from the hydraulic system by pressurising and operating through its functions several times.
- Check the tractor oil level and top up if necessary.
- Check that the implement is correctly hitched to the loader (see “IMPLEMENT HITCHING”). Press the implement down on the ground (until the tractor's front wheels lift up) to check that it locks in place correctly. If the loader is fitted with the SPEED-LINK or FAST-LOCK option, alternate between "locked" and "released" several times. Check that the indicator rod is correctly adjusted (see “LEVEL INDICATOR”).
- Check the loader's mechanical condition (any cracks, distortion, end stop matting, clearance, parking stands, etc.).

 **CAUTION: For tractor maintenance operations, the tractor engine must be stopped and it is strongly recommended to unhitch the loader. Unhitching is a simple, quick operation that provides the best guarantees of safety and efficiency for tractor maintenance.**

12.1.1 Static test procedure

Check the structural integrity of the front loader and the loader's compliance with its technical specifications before use:

- Examine the loader's overall structure for cracks, faulty welds, or warping.
- Check the fasteners (bolts, nuts, rivets) to make sure they are properly tightened and do not show signs of damage.
- Check the condition of the loader and pivot points for wear or excessive play (see “MAINTENANCE”).
- Ensure that the loader complies with the technical specifications (see “TECHNICAL SPECIFICATIONS”).
- Check the rams and hydraulic components (hoses, connectors, etc.) for damage or wear.

 **CAUTION: All loader tests must be carried out by the operator from their cab. Nobody should be allowed in the area in which the loader is moving while it is in operation.**

12.1.2 Dynamic test procedure

Test the loader's operational performance and safety under actual usage conditions:

- Hitch the loader with an implement to the tractor (see “LOADER HITCHING” and “IMPLEMENT HITCHING”).
- Raise and lower the loader to different heights to ensure that everything is moving properly.
- Load the implement with the maximum authorised weight and check the loader's ability to lift and hold the load (see “TECHNICAL SPECIFICATIONS”).

- With the loader still hitched to it, drive the tractor across different terrain (flat, slope, rough). Carry out turning and reversing manoeuvres to check stability and responsiveness.
- Check the hydraulic rams and pipes for leaks.
- Check that the lifting/dumping safety system is working properly (see "LIFTING/DUMPING SAFETY"). (OPTION)

NOTE: Make sure the control levers are in neutral before checking the operation of the front loader/tractor unit.

⚠ CAUTION: All loader tests must be carried out by the operator from their cab. Nobody should be allowed in the area in which the loader is moving while it is in operation.

13. Level indicator

The level indicator enables implement positioning as the loader is descending. It is located on the left side of the loader. It can be adjusted to suit the implement being used.

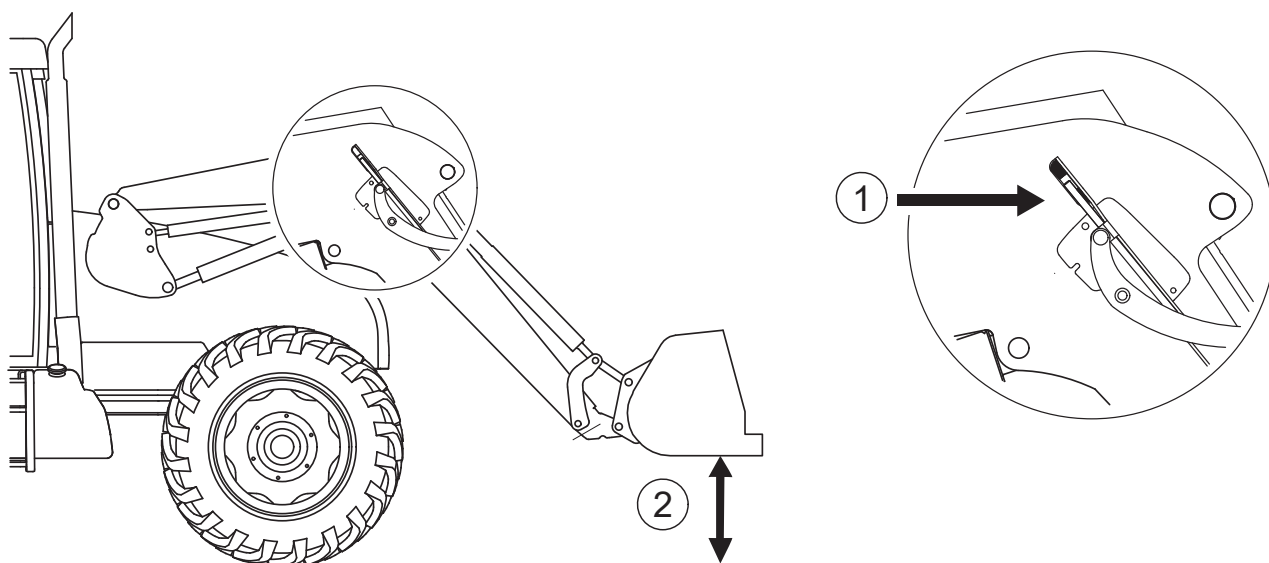

14. SHOCK ELIMINATOR System

Shocks are eliminated during movement or when stopping the loader quickly when lowering. This system softens impacts on the tractor and jolting in the cab.

NOTE : The Shock Eliminator can be activated or deactivated directly in the driver's seat (electric isolation). See manual specific to e-PILOT S.

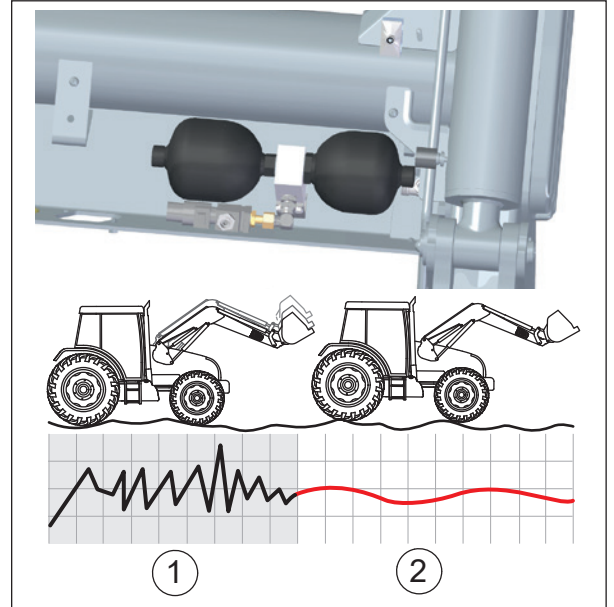

(1) Without SHOCK ELIMINATOR
(2) With SHOCK ELIMINATOR

NOTE : if controlled using tractor's original control valves, activate or deactivate the Shock Eliminator using the switch in the cab.

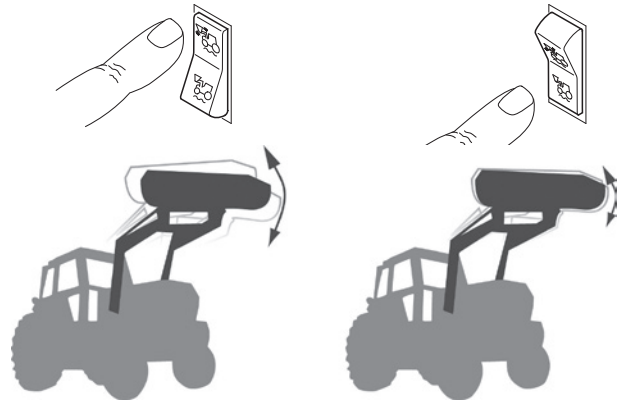

15. AUTO-LEVEL System

Automatic implement level reset, using the AUTO-LEVEL System (optional), is available for loaders that are controlled using MX "e-PILOT S" control valves.

15.1 Implement position adjustment

The implement position is adjusted at the indicator rod. See pictures opposite.

- Put the implement into the desired position.
- Lower the implement to the ground.
- Loosen the wingnut (1).
- Position the end of the rod in front of the sensor (2).
- Tighten the wingnut (1).

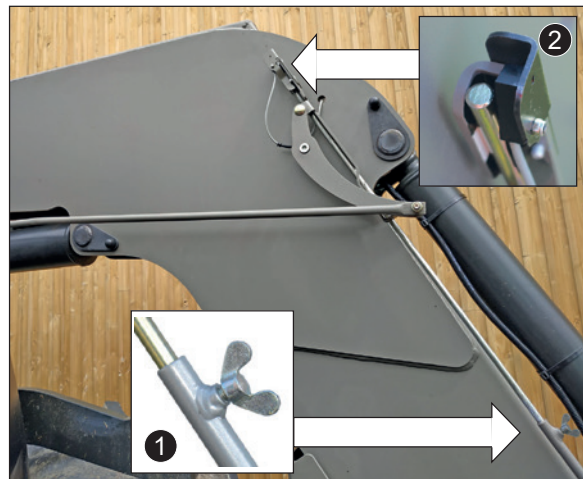

15.2 Automatic implement position reset

The system operates in both directions: crowding and dumping. If the implement is dumped when the AUTO-LEVEL System is activated, the loader crowds. If the implement is crowded, the loader dumps.

Control: see specific manual for e-PILOT S.

16. AUTO-UNLOAD System

The bucket/grab synchronisation (optional) operates both ways:

- Opening the grab/Tipping the bucket.
- Crowding the bucket/Closing the grab.

The AUTO-UNLOAD System only operates if the loader is fitted with a 3rd function.

e-PILOT S control: see specific e-PILOT S information (function: AUTO-UNLOAD System).

NOTE: To optimise use of the AUTO-UNLOAD System, we recommend activating the system while dumping into a trailer, when the implement is in the horizontal position.



17. Safety when lifting and dumping

 **This device is essential for working when people are present near the load (optional).**

In compliance with standard EN 12525 + A2 2010, it can be disengaged for working when no one is near the load. The movements can then be carried out, with no loss of power or speed of execution. Uniquely, this equipment is compatible with the Shock Eliminator and the notched floating position.

17.1 Extract from the Front Loaders standard EN12525 + A2 2010:

"4.4.4 Protection against unintentional lowering

If the front loader is also designed for lifting operations requiring the presence of someone near the load when the loader is in raised position, the hydraulic circuit of the lifting arm rams must, in compliance with Annex E, be fitted with a safety device to prevent accidental lowering of the lifting arm. This device must remain active in the event of a failure of the control circuit's power supply.

If this safety device can be switched on/off or activated/deactivated for operations that do not require the presence of someone near the load, then the following additional specifications apply:

- it must be possible to switch on/off or activate/deactivate the safety device from the driving position;
- it must be possible to switch on or activate the safety device from the ground without being close to the load;
- the operating device to switch off or deactivate the safety device must be designed and located so that the operator cannot operate it unintentionally;
- the status (on/off or activated/deactivated) of the safety device must be clearly indicated and clearly visible from the driving position and from the loading area.

In compliance with 7.1.2, the correct operating method, along with appropriate warnings, must be explained in the instruction manual.

The loader must be fitted with a warning stating that for lifting operations requiring the presence of someone near the load, the safety device must be switched on (activated) when the loader is in the raised position (see 7.2).

Information on the use of front loaders that are not designed for lifting operations requiring the presence of an operator near the load when the loader is in raised position must comply with 7.1.4 and 7.2. "

" **Annex E** (normative)

Test method and acceptance criteria for means of avoiding unintentional lowering

E.1 Terms and definitions

E.1.1

discharge device

hydraulic valve(s) used to simulate a break in the loader's hydraulic lines.

E.1.2

test load

weight $(50 \pm 10)\%$ of nominal lifting capacity specified by the manufacturer of the loader.

E.2 Test procedure

The test specified from E.2.1 to E.2.2 must be carried out according to each of the following conditions:

- position held after lowering the test load to a height of (1 ± 0.1) m (static test);
- position held after lifting the test load to a height of (1 ± 0.1) m (static test);
and at hydraulic system oil temperatures of between 40°C and 50°C.

E.2.1 The discharge device between the lifting rams and the control valve must be open

E.2.2 The total downward movement of the load must be measured at the implement's pivot point

E.3 Acceptance criterion

The total downward movement measured in E.2.2, during the first 10 seconds, must not exceed:

- 100 mm, if the safety device is switched off or manually deactivated;
- 300 mm, if the safety device is permanently activated.

After 5 min, additional downward movement must not exceed 100 mm. "

17.2 Use of the lifting and dumping safety device

The hydraulic circuit of the lifting and dumping rams is fitted with a safety device (1) and (2).

By default, the safety device is enabled.

When the user presses the button in the cab (3) (secure button), the safety device is disabled and the red indicator lights are illuminated on:

- on the button in the cab (3),
- on the external button (4),
- on the 2 solenoid valve connectors of the lifting rams (5).

Button function (3):

- Press (A): safety device disabled.
- Press (B): safety device actuated.

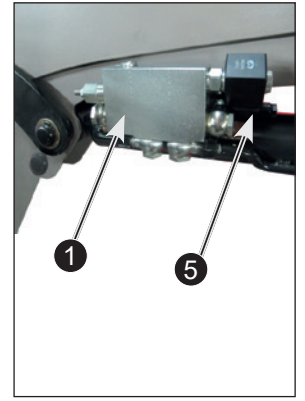
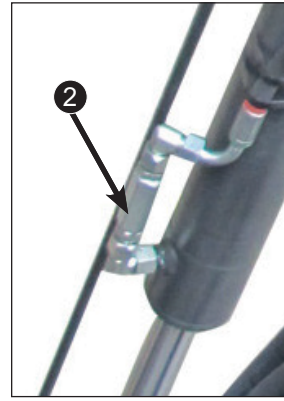

NOTE: As soon as the tractor is switched off, the safety device is automatically actuated.

⚠ Caution: Deactivation of the safety device is only permitted when there is no-one in the vicinity of the load. In this case, the maintained floating position and the Shock Eliminator are compatible.

By pressing buttons (3) or (4), the safety device is re-enabled (red indicator lights off).



Button (4) is only used to re-enable the safety device from outside the cab.

In this case, the red indicator lights go off.

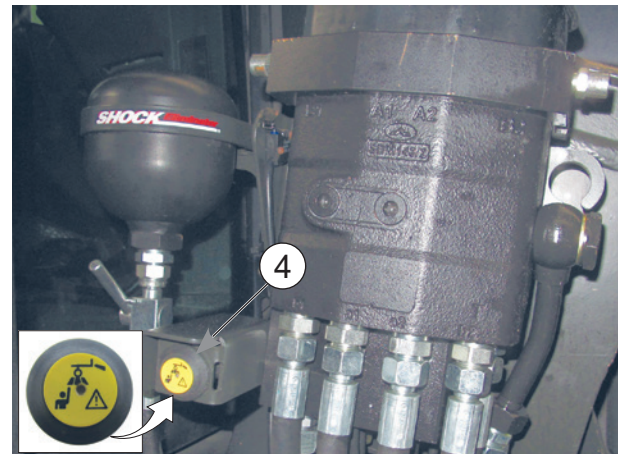

18. Maintenance

⚠ Drain the tractor's hydraulic circuit regularly and change the filters in accordance with the manufacturer's recommendation.

Contaminated oil ceases to lubricate, causing wear on all the hydraulic components (pumps, control valves, rams). Even clear oil may be spent.

Maintenance operations must be performed by **competent persons, authorised by the dealer**. If not, these operations come under the sole responsibility of the person carrying out the work.

PPE (Personal Protective Equipment) must be worn during all maintenance operations (please refer to the "PPE table". See the "Safety Rules" chapter).

Switch off the tractor engine before carrying out any maintenance work on the loader and/or its implements.

For loader maintenance operations, never work on mechanical parts under stress or on a pressurised circuit, hydraulic part, or electrical circuit that is switched on.

For tractor maintenance operations, it is strongly recommended to unhitch the loader. Unhitching is a simple, quick operation that provides the best guarantees of safety and efficiency for tractor maintenance.

For any work with the lifted loader, the loader must be locked in position:
Unlocking the MACH System, or closure of the lifting rams supply valve for a loader without MACH System. (See the "LOADER UNHITCHING" chapter).

Lubricate the MACH System locking system every 3 months.

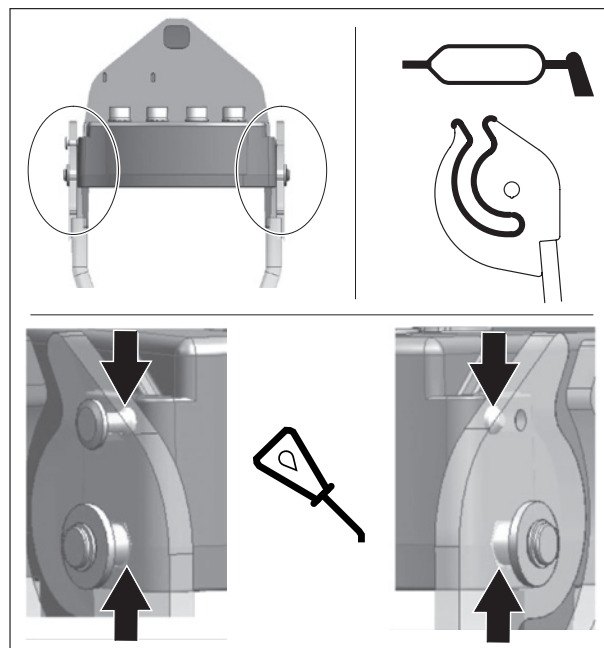

Lubricate every 10 hours and after each wash (**water drives grease out**), particularly after using a pressure washer. See the lubrication points opposite.
Recommended type of grease for maintenance: NLGI 2

When using a pressure washer, avoid spraying water on electric components.

Clean the implement and the front of the loader after every use. Slurry acid, fertiliser and silage can damage paint, steel and pivot points.

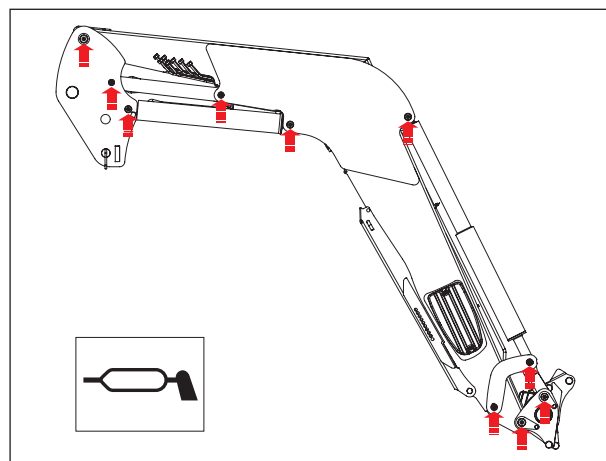

⚠ CAUTION: Oil escaping under pressure can have sufficient force to penetrate the skin and cause serious injury. Before disconnecting the hoses, ensure that you have released all the pressure. Before pressurising the system, check that all connectors are tight and that the hoses and hydraulic circuit are not damaged.

CAUTION: Oil escaping from a very small hole can be almost invisible. Use a piece of cardboard or wood, rather than your hands, to detect suspected leaks. If you are injured by a leak under pressure, seek immediate medical attention. An infection or serious reaction may develop if appropriate medical treatment is not immediately provided.

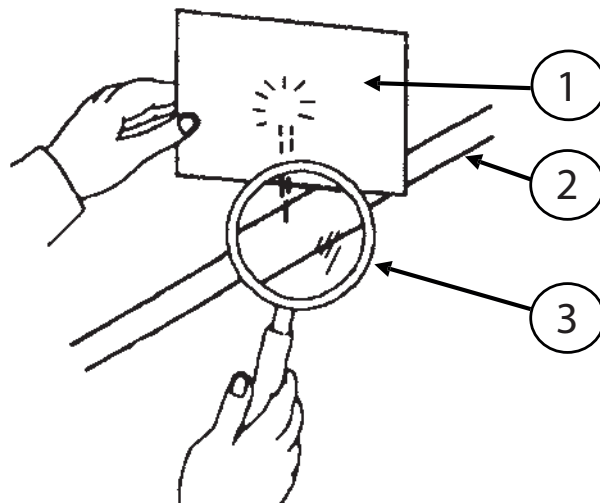

- (1) Cardboard.
- (2) Hydraulic circuit.
- (3) Magnifying glass.

Every month, or more often with heavy use, check:

- The condition of the loader and/or implement pivot points. As required, replace wear bushes and/or the pins.
- Wear bushes must be replaced if they are less than 1 mm thick.
- The level of the tractor's hydraulic oil and the sealing of the hydraulic circuit. If you find any internal or external leaks on hydraulic components (rams, pipes, connectors, Mach, couplings, etc.), contact your dealer.
- The condition of the hoses: replace them if any cracks or oil seepages appear.
- Correct operation of the monolever (cables, play, locking, etc.).
- Electric cabling condition. Contact your dealer if any connectors or cables are damaged.
- Mechanical condition (any cracks, distortion, end stop matting, clearance, parking stands, etc.).
- Contact your dealer if there is any abnormal wear.
- Scrapping: please contact your dealer or a company specialising in materials recycling.
- Check bracket tightness after 10 and 50 hours work, then every 100 hours or when the tractor engine is drained. Contact your dealer, if there is any loosening.

IMPORTANT: All fasteners/screws needing to be retightened must be inspected, replaced if necessary, cleaned and reassembled using thread locking compound.

Tighten fasteners/screws in accordance with the tightening torque recommended in the table below. (Do not use an air gun to screw or tighten screws/fasteners on the tractor.)

Check the tightness of the bracket after 10 and 50 hours' work, then every 100 hours or when the tractor's engine oil is changed (without bracket). If loose, please contact your dealer.

IMPORTANT: Before use, check that all screws/fasteners have the correct tightening torque.

Any screws that need to be retightened should be inspected, replaced if necessary, cleaned and reassembled using thread locking compound.

Tighten the screws at the tightening torque specified in the table below.

(Do not use an air gun to screw or tighten the screws/fasteners on the tractor).

— Tightening torques (Nm)

Class of bolt	Dowel marking (ISO 898)	Thread											
		M 5	M 6	M 8	M 10	M 12	M 14	M 16	M 18	M 20	M 22	M 24	M 27
8.8	○	5.2	9	21.6	43	73	117	180	259	363	495	625	915
10.9	□	7.6	13.2	31.8	63	108	172	264	369	517	704*	890	1304
12.9	△	8.9	15.4	37.2	73	126	201	309	432	605	824	1041	1526

18.1 Bracket maintenance specifications

Screwed linkage	Inspection schedule			
	Indication on tractor hour meter			Interval
	100h or first overhaul of new tractor*	600h or second tractor overhaul*	3000h	
Check that bolts between the tractor and our supply and among our parts are tightened to the recommended torque.	X	X		Then every 600h
Check that stem bolts are tightened to the recommended torque.	X		X	Then every 3000 hours

*depending on which is the first to happen.

! WARNING: To avoid any risk of serious or fatal accidents:

- Regularly check that the nuts and screws are properly tightened; refer to the checking table below.
- All screws requiring retightening must be inspected and, if necessary, replaced.
- Impact wrenches must not be used to screw or tighten the fasteners used on the tractor or on the parts of our supplied product.

18.2 Troubleshooting

Any fault diagnosis and/or removal of parts must be carried out by a professional who is to start by ensuring that the work will be carried out safely, with minimal risk to themselves and their environment, especially in the case of work on a lifted loader.

Maintenance operations must be performed by qualified personnel, as authorised by the dealer. If this is not the case, the person carrying out the work will be fully liable for these operations.

It is strongly recommended to unhitch the loader to ensure safety and maintenance efficiency.

For any maintenance operation on a loader and/or its implements:

- Switch off the tractor's engine.
- PPE must be worn.
- The loader must be on the ground with the implement and any accessories (grab, rotor, etc.) at rest.
- Decompress the hydraulic circuit.

PROBLEM	PROBABLE REASON	CORRECTIVE STEPS
LIFTING OR DUMPING INOPERATIVE	THE HYDRAULIC COUPLINGS ARE NOT CONNECTED PROPERLY.	CHECK THE CONNECTION. REPLACE IF NECESSARY.
	THE TRACTOR OIL LEVEL IS TOO LOW.	CHECK AND TOP UP THE OIL LEVEL ON THE TRACTOR.
	THE LOADER CONTROL VALVE OR FEED CONTROL VALVE PRESSURE LIMITER IS STUCK IN THE OPEN POSITION.	CONTACT YOUR LOCAL DEALER.
	MALFUNCTION IN THE TRACTOR'S HYDRAULIC PUMP.	CONTACT YOUR LOCAL DEALER.
IMPLEMENT RAM INOPERATIVE	THE COUPLINGS ARE NOT CONNECTED PROPERLY.	CHECK THE CONNECTION. REPLACE IF NECESSARY.
	FAULT IN THE ELECTRIC CABLING.	INSPECT AND REPLACE IF NECESSARY.
	THE SOLENOID VALVE HAS SEIZED UP.	CONTACT YOUR LOCAL DEALER.
	THE RAM SEAL IS DAMAGED (LEAKING).	CONTACT YOUR LOCAL DEALER.
DUMPING AND LIFTING RAM CONTROL LEVERS OPERATE IN REVERSE	FAULTY COUPLINGS.	REPLACE THE COUPLINGS.
	THE HYDRAULIC HOSES ARE NOT CONNECTED PROPERLY.	CONNECT THE HOSES AS INDICATED.
AIR IS PRESENT IN THE HYDRAULIC SYSTEM (FOAMING)	THE CABLE CONTROL HAS NOT BEEN CONNECTED PROPERLY.	CONTACT YOUR LOCAL DEALER.
	THE TRACTOR OIL LEVEL IS TOO LOW.	CHECK AND TOP UP THE OIL LEVEL ON THE TRACTOR.
	AIR LEAK ON THE SUCTION SIDE OF THE HYDRAULIC PUMP.	CONTACT YOUR LOCAL DEALER.

	THE TRACTOR OIL LEVEL IS TOO LOW OR THE OIL IS COLD.	CHECK AND TOP UP THE OIL LEVEL ON THE TRACTOR. ALLOW THE OIL TO REACH OPERATING TEMPERATURE.
	AIR IS PRESENT IN THE HYDRAULIC SYSTEM	BLEED THE HYDRAULIC SYSTEM. CONTACT YOUR LOCAL DEALER IF THE PROBLEM PERSISTS.
	THE LOAD WEIGHT IS HIGHER THAN THE MAXIMUM LOAD SPECIFIED FOR THE LOADER.	REDUCE THE LOAD IN THE IMPLEMENT (SEE "TECHNICAL SPECIFICATIONS").
	THE COUPLINGS ARE NOT FULLY LOCKED TOGETHER.	CHECK THE CONNECTION AND REPAIR OR REPLACE THE COUPLINGS IF NECESSARY.
LIFTING IS SLOW OR JERKY	THE TRACTOR ENGINE SPEED IS TOO LOW (LOW HYDRAULIC PUMP SPEED).	INCREASE THE TRACTOR ENGINE SPEED TO IMPROVE LOADER PERFORMANCE.
	THE CONTROL VALVE LEVER CABLES HAVE SEIZED UP OR ARE FAULTY.	CONTACT YOUR LOCAL DEALER.
	THE MACH SYSTEM HOUSING IS NOT FULLY LOCKED IN PLACE	CHECK THAT THE MACH SYSTEM HOUSING IS CORRECTLY LOCKED IN PLACE (HANDLE OPERATED AS FAR AS IT WILL GO).
	RAM LEAKAGE.	CONTACT YOUR LOCAL DEALER
	MALFUNCTION OF THE PRESSURE LIMITER OR THE PRESSURE LIMITER IS SET TOO AN EXCESSIVELY LOW VALUE.	CONTACT YOUR LOCAL DEALER.
	HOSE/PIPE TWISTED OR CLAMPED.	CONTACT YOUR LOCAL DEALER.
	INSUFFICIENT HYDRAULIC PUMP CAPACITY ON THE TRACTOR	CONTACT YOUR LOCAL DEALER.
	PRESSURE LIMITER IS POORLY CALIBRATED.	CONTACT YOUR LOCAL DEALER.
INSUFFICIENT LIFTING CAPACITY	THE LOAD WEIGHT IS HIGHER THAN THE MAXIMUM LOAD SPECIFIED FOR THE LOADER.	REDUCE THE LOAD IN THE IMPLEMENT (SEE "TECHNICAL SPECIFICATIONS").
	TRACTOR ENGINE SPEED TOO LOW.	INCREASE THE ENGINE SPEED.
	FAULTY TRACTOR HYDRAULIC PUMP.	CONTACT YOUR LOCAL DEALER
THE LOADER LOWERS ITSELF DESPITE THE CONTROL LEVERS BEING IN NEUTRAL	LEAK IN THE LIFTING RAMS.	CONTACT YOUR LOCAL DEALER.
	ABNORMAL INTERNAL LEAKAGE IN THE LEVER CONTROL VALVE.	CONTACT YOUR LOCAL DEALER.
CAUTION: SOME TOLERANCE MAY BE REQUIRED (BETWEEN 0 AND 8 CM)	THE LOADER CONTROL LEVER SPOOL VALVE DOES NOT RETURN TO ITS NEUTRAL POSITION.	CONTACT YOUR LOCAL DEALER.

THE LOADER CONTROL LEVER SPOOL VALVE DOES NOT RETURN TO ITS NEUTRAL POSITION.	THE CONTROL LEVER SPOOL DOES NOT MOVE FREELY (POLLUTION).	CONTACT YOUR LOCAL DEALER.
	THE NEUTRAL POSITION OF THE CABLE MONOLEVER IS POORLY CALIBRATED.	CONTACT YOUR LOCAL DEALER.
NOTE: CHECK THAT THE CONTROL LEVERS ARE IN NEUTRAL.	THE CONTROL LEVER OR CABLE SYSTEM HAS SEIZED UP.	CONTACT YOUR LOCAL DEALER.
EXTERNAL OIL LEAK	DAMAGED HYDRAULIC HOSES, PIPES, THREADED CONNECTORS OR SEALS.	CONTACT YOUR LOCAL DEALER.
	LOOSE HYDRAULIC HOSES.	TIGHTEN THE HOSES.
	DAMAGED SEALS ON THE LEVER CONTROL VALVE.	CONTACT YOUR LOCAL DEALER
	LEAKING RAM OR DAMAGED RAM ROD.	THE RAM SHOULD BE REPLACED. CONTACT YOUR LOCAL DEALER.
	THE LOADER CONTROL LEVER OR SOLENOID VALVE IS DAMAGED/ WORN.	CONTACT YOUR LOCAL DEALER.
THE RAM RODS ARE BENDING	EXCESSIVELY FAST BACKWARD MOTION SCRAPING.	THE RAM SHOULD BE REPLACED. CONTACT YOUR LOCAL DEALER.
	SUDDEN AND EXCEPTIONALLY HIGH LOAD DURING USE.	THE RAM SHOULD BE REPLACED. CONTACT YOUR LOCAL DEALER.
SHOCK ABSORPTION IS INOPERATIVE.	FAULTY ACCUMULATOR.	THE ACCUMULATOR NEEDS TO BE REFILLED. PLEASE CONTACT YOUR LOCAL DEALER.
NOTE: SHOCK ELIMINATOR IS ONLY AVAILABLE AS AN OPTION. FIRST OF ALL, CHECK THAT SHOCK ELIMINATOR HAS BEEN FITTED.	THE LIFTING/DUMPING SAFETY OPTION IS FITTED AND ACTIVE ON THE LOADER.	THE SHOCK ELIMINATOR OPTION IS NOT COMPATIBLE WITH THE LIFTING/DUMPING SAFETY OPTION.
	THE SHOCK ELIMINATOR VALVE (AVAILABLE ON OPTION) IS CLOSED OR FAULTY.	THE VALVE NEEDS TO BE REPLACED. CONTACT YOUR LOCAL DEALER.
NOTE: IN SOME CONFIGURATIONS, THIS MAY BE MANDATORY.	THE SOLENOID VALVE IS FAULTY/ HAS NOT BEEN ACTIVATED.	CHECK THAT THE SOLENOID VALVE IS CONNECTED AND SUPPLIED WITH 12 V. CONTACT YOUR DEALER IF THE PROBLEM PERSISTS.
THE HYDRAULIC 3RD FUNCTION IS INOPERATIVE	THE SOLENOID VALVE IS FAULTY/ HAS NOT BEEN ACTIVATED.	CHECK THAT THE SOLENOID VALVE IS CONNECTED AND SUPPLIED WITH 12 V. CONTACT YOUR DEALER IF THE PROBLEM PERSISTS.
THE HYDRAULIC 4TH FUNCTION IS INOPERATIVE	THE SOLENOID VALVE IS FAULTY/ HAS NOT BEEN ACTIVATED.	CHECK THAT THE SOLENOID VALVE IS CONNECTED AND SUPPLIED WITH 12 V. CONTACT YOUR DEALER IF THE PROBLEM PERSISTS.

THE HYDRAULIC IMPLEMENT
LOCK IS INOPERATIVE

(FAST-LOCK OR SPEED-LINK
OPTION)

THE SOLENOID VALVE IS FAULTY/
HAS NOT BEEN ACTIVATED.

CHECK THAT THE SOLENOID VALVE IS
CONNECTED AND SUPPLIED WITH 12
V. CONTACT YOUR DEALER IF THE
PROBLEM PERSISTS.

19. Recycling MX products

Hydraulic system

- At the end of life, MX products must be drained of hydraulic oil by authorised repairers.
- The hydraulic hoses must be removed before the equipment can be recycled.
- All MX product owners must comply with these environmentally-friendly precautions if they decide to dismantle end-of-life products themselves.

Disposal of hazardous waste (oils and hoses)

- Hydraulic oils must be stored in the containers or drums provided for this purpose and sent to authorised services.
- Steel connectors can be separated from the rubber hydraulic hose.
- Steel end caps are recycled as scrap by authorised services.
- Rubber hoses should be placed in watertight containers and sent for processing by authorised services.

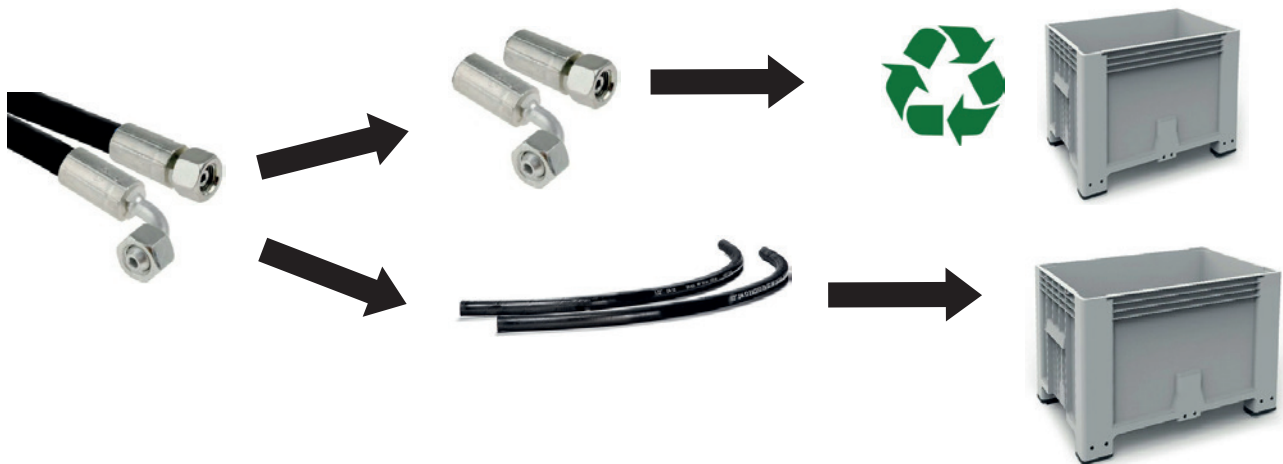

High-tech MX product components and electrical and electronic equipment:

- Waste electrical and electronic equipment (WEEE) present in MX products is removed and disposed of by authorised services for recovery.



Recycling of decontaminated MX products

- Decontaminated MX products are sent to authorised services for iron and metal recycling.

20. Technical specifications

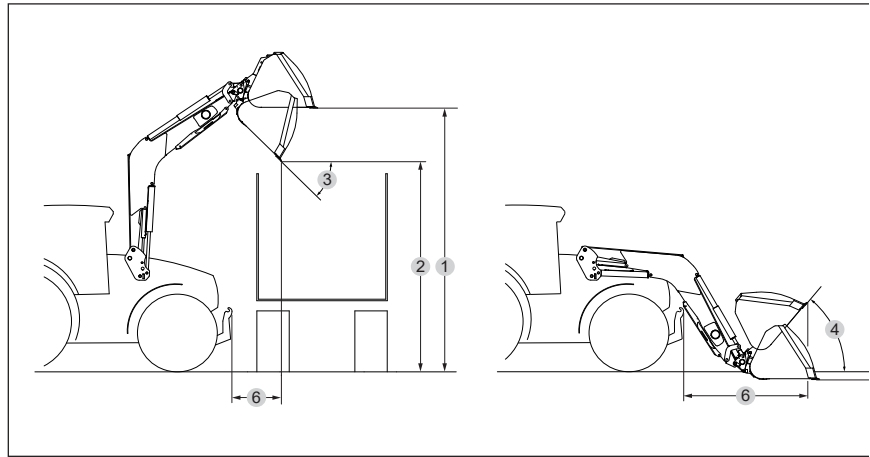
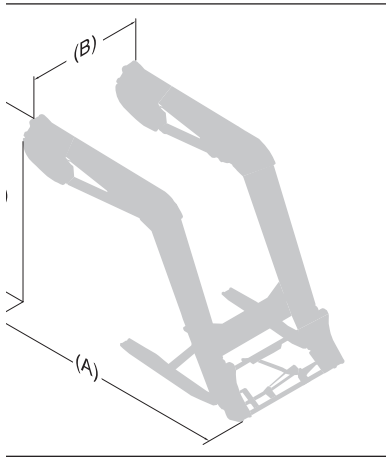

	TX420	TX425	TX430
Length (A)	2.90 m	3.00 m	3.30 m
Width (B)	1.50 m	1.50 m	1.50 m
Height (C)	2.25 m	2.40 m	2.40 m
Max. weight	1080 kg	1180 kg	1270 kg
Maximum height at implement pivot*	4.87 m	5.10 m	5.50 m
Max. height under horizontal bucket (1) #	4.55 m	4.80 m	5.20 m
Max. height under dumped bucket (2) #	3.40 m	3.68 m	4.14 m
Front range (6) # High / Low	0.72 m / 2.02 m	0.97 m / 2.10 m	0.95 m / 2.37 m
Digging depth (5) #	0.15 m	0.15 m	0.15 m
Dumping angle at full height (3) #	50°	50°	45°
Crowd angle at ground level (4) #	48.5°	48.5°	50.5°
Lift force at implement pivot, ground level*	4000 kg	4100 kg	4100 kg
Lift capacity at implement pivot over entire lifting range*	3250 kg	3650 kg	3650 kg
Payload on pallet at 0.60 m out on forks			
On the ground	3550 kg	3700 kg	3700 kg
At 2 m above ground	3450 kg	3650 kg	3650 kg
At 3 m above ground	3260 kg	3450 kg	3450 kg
At max. height	2950 kg	3200 kg	3200 kg
Lifting time	6.7 sec	8.3 sec	9 sec
Dumping time	1.5 sec	1.5 sec	1.5 sec

NOTE : Specifications determined at 205 bar pressure and 80 litres/min flow rate.

Data may vary depending on the type of tractor being equipped and may be subject to modification without notice.

Figures provided for a high-capacity bucket BC HD, Euro hitching. Front range given for CLAAS Axion 800.

* Payloads only. The figures at ground level and at the implement pivot axis are not usable.

DECLARATION OF CONFORMITY



The manufacturer:

M-extend France SAS

Registered office: 19, Rue de Rennes, 35690 Acigné (France).

Registered with the RCS of Rennes under number 639 200 260.

Hereby declares that the material :

Front loader T406 or T408 or T408+ or T410 or T410+ or T412 or T412+ or T414 or T417 or T418 or TX420 or TX425 or TX430

or

Front loader U503 or U504 or U505 or U506 or U506+ or U507 or U508 or U508+ or U509 or U510 or U510+ or U511 or U512 or U512+ or U514 or U514+

or

Front loader A104 or A106 or A110 or F303 or F304

or

Front loader C1 or C1s or C2u or C2 or C2+ or C3u or C3 or C3+ or C4 or C4+

or

Loader implement BMS or BRDS or BQU or BF + GF or CGU or TR or BMSC or CGC or TRC or BT or BR or BC or BF or BMSU or BRU or BFU or CL or BRC or BFC or LC or CG or BP or SG or BB or PCS or LS or PG

or

Implement for telescopic handler loader BMSA or CGA or BTA or TR or BCA or BCDA

or

Feeding bucket BD1202 or BD 1402 or BD 2002 or BD 2402 or BD 3102

or

Manubal L40 or L400 or L400HD or L500 or L6000 or C30 or C40 or U40 or V40 or V60 or V500 or W500 or V400HD or V5000HD or V7000HD

or

Front linkage R04 or R05 or R06 or R08 or R09 or R10 or R12 or R16 or R20 or R28 or R38 or R53

or

Weight M250 or M400 or MM600 or MM900 or MM1200 or MM1500 or MM400AD or MBX or MXS 250 or MXS 400 or MXS 600 or BOX 100L or BOX 150L or MBX XS

or

Multibumper

serial number:

please write in the box above the serial number given on the equipment's nameplate.

included in the list of serial numbers 49999 11 001 to 499999 24 365,

is in conformity with the Machinery Directive 2006/42/EC

(and satisfies standard NF EN 12525+A2 of May 2010).

and with the Supply of Machinery (Safety) Regulations 2008

M-extend France SAS, 19 rue de Rennes at Acigné (35690), is authorised to prepare the technical file.

Acigné, 17 January 2024.

B. Gauchenot
CEO



M-extend France SAS
19, rue de Rennes
B.P. 83221
FR-35690 ACIGNÉ
Email : contact@m-x.eu
Web : www.m-x.eu