



RAISE YOUR EXPECTATIONS

LOADER

MX

Fitting instructions

**Please read these fitting instructions carefully before assembling the
MX loader**

CONTENTS

1. SAFETY RULES	6
2. HANDLING	8
2.1 MX loaders packaged on a pallet	8
2.2 Handling the MX loader	10
3. LOADER PREPARATION	11
3.1 T400 series, U500 series, A100 series loaders	11
4. LOADER HITCHING	13
4.1 Pre-hitching checks	13
4.2 T400 series, U500 series, A100 series loaders	13
4.3 TX400, F300 series and COMPACT loaders	15
4.4 Final checks	15
5. PUTTING THE LOADER INTO OPERATION	16
6. IMPLEMENT HITCHING	16
7. WASHING	17
8. TIGHTENING TORQUE:	17
8.1 Bracket maintenance specifications	17

1. Safety rules

 **The loader is a complex machine that should only be used after formal instructional handover.**

The demonstration of the equipment to be delivered should include:

- The safety rules.
- Hitching and unhitching the loader.
- Hitching and unhitching the implements.
- Full use of the controls.

IMPORTANT: For the attention of the vendor

You are legally obliged to provide proof that you have properly carried out the loader handover and supplied the user handbook to your customer. It is recommended that you provide a statement to this effect on the delivery slip.

The MX product is intended for professional users. However, if there is any likelihood of the MX product being operated by a non-professional user, the dealer is liable for informing the user of their need to request a printed copy of the user manual from M-extend including the basic safety information for starting up the machine or product and using it safely.

- Before use, the vendor and the installer should be sure that the loader-tractor unit and the implement-loader unit are compatible. They should refer to the current MX price list.
- PPE (Personal Protective Equipment) must be worn (protective equipment for both hands and feet).
- The fitting instructions supplied with the MX loader are intended for anyone responsible for assembling, installing, operating, adjusting, maintaining, troubleshooting, storing and transporting the MX loader and its implements.
- Installation and servicing of MX products must be performed by competent persons authorised by the dealer. These persons must have read the MX fitting documents and rules.
- The tractor should at the very least be fitted with a roll-over protective structure (ROPS), which should be in the active position when using the loader.
- MX products are designed to be used at the maximum hydraulic pressure indicated by the manufacturer for the tractor's specifications. Use of excess pressure will result in additional strain and will therefore invalidate the MX equipment warranty.
- In compliance with standard EN 12525, the controls for operating the loader and implements must be of the "sustained action" type, except for the floating position for lifting and/or dumping, which can be held in place by a notching system.
- Breaking lead seals will void any liability on the part of MX for all its equipment.
- Any assembly of the MX loader not in accordance with the recommendations of the MX price list in force at the purchase date voids the MX guarantee for the entire unit supplied.
- Any modification to any part of the equipment supplied by MX (implements, loader, frame, etc.), or the installation of a non-MX implement or component installed on the MX loader will void the MX guarantee for the entire unit supplied.
- Any modification made to the MX loader and its implements or usage thereof for purposes other than the handling of materials for which they were designed, in particular the transportation of people or any handling operations performed above people, are PROHIBITED.
- Use only spare parts and accessories that comply with MX's recommendations. Do not carry out any modifications to your MX loader or its accessories yourself or have anyone else do so (mechanical, electrical, hydraulic or pneumatic components) without seeking prior approval in writing from MX. Failure to comply with these rules may make your MX loader hazardous to operate. In the event of damage or injury, MX shall not be held responsible in any way.
- The warranty will immediately cease to be in effect if the user fails to comply with the standards and instructions for use

and maintenance of the MX loader, as set out in the "Fitting instructions" and the "User manual".

2. Handling

2.1 MX loaders packaged on a pallet

Ensure all parts of the loader are firmly bound together to remove it from the pallet (See loader unpacking instructions).

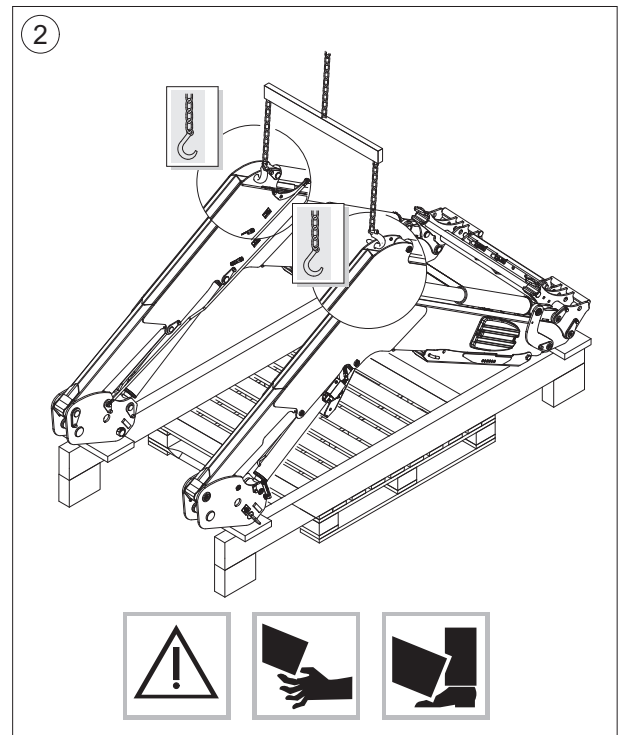
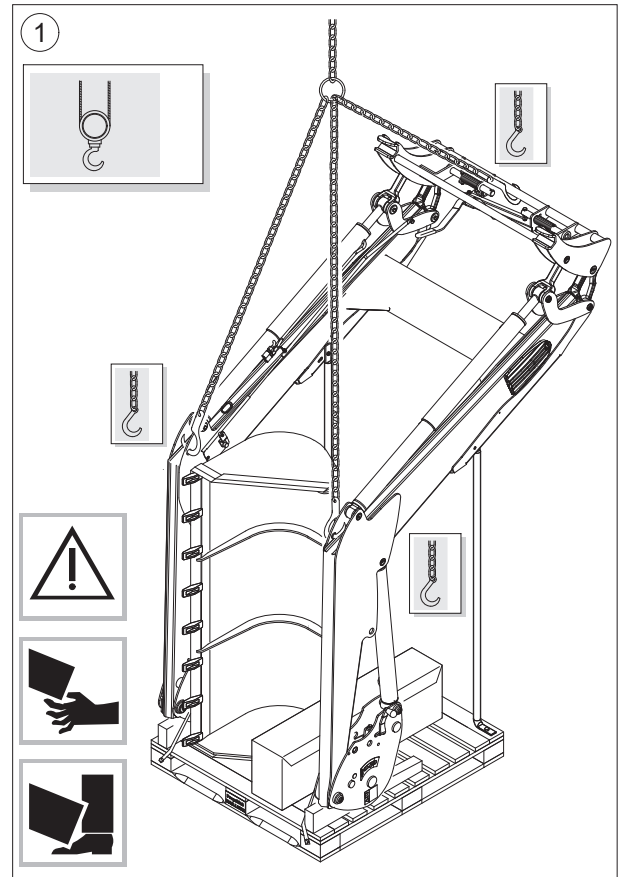

(1) T400, A100.

(2) TX400, T400, A100.

Ensure all parts of the loader are firmly bound together to remove it from the pallet (See loader unpacking instructions).

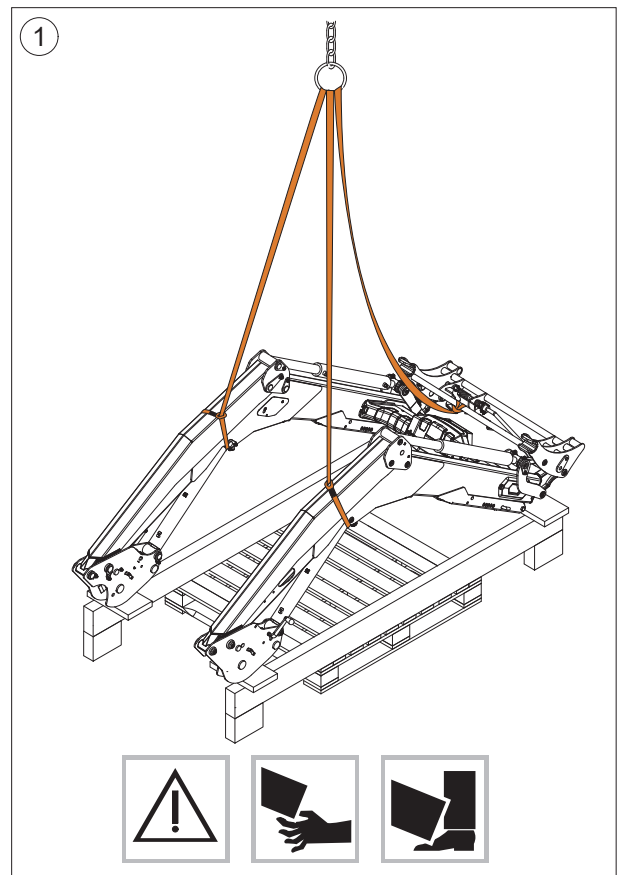
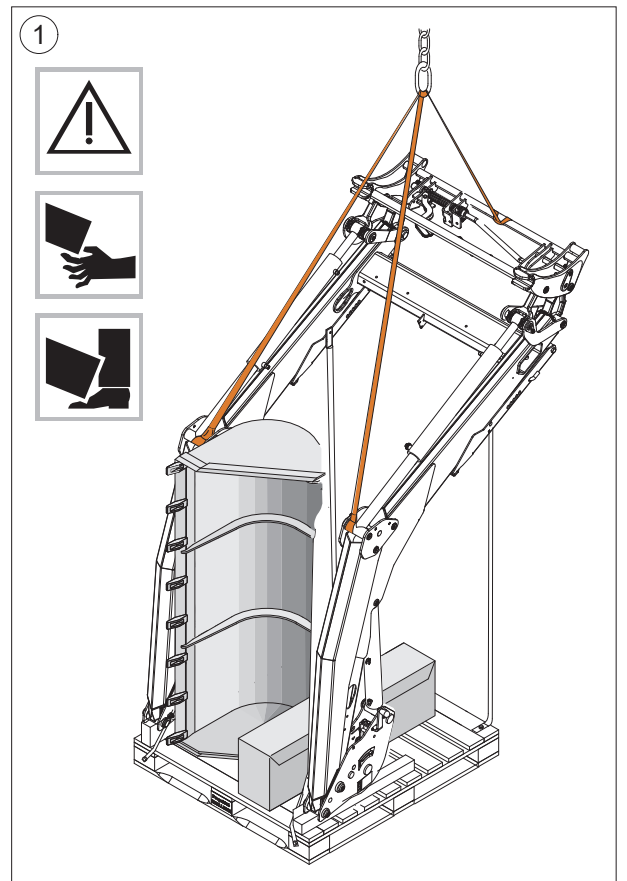

(1) U500.

2.2 Handling the MX loader

Use anchorage points (except U500 series).

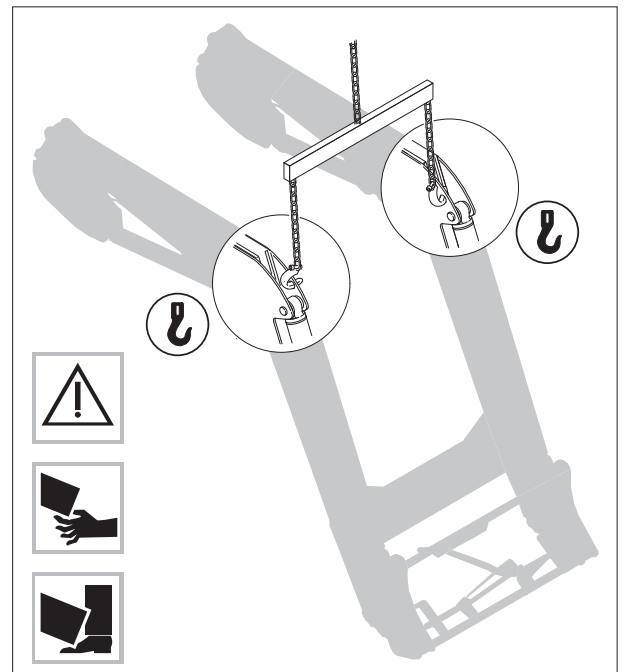

Handling U500 series loaders

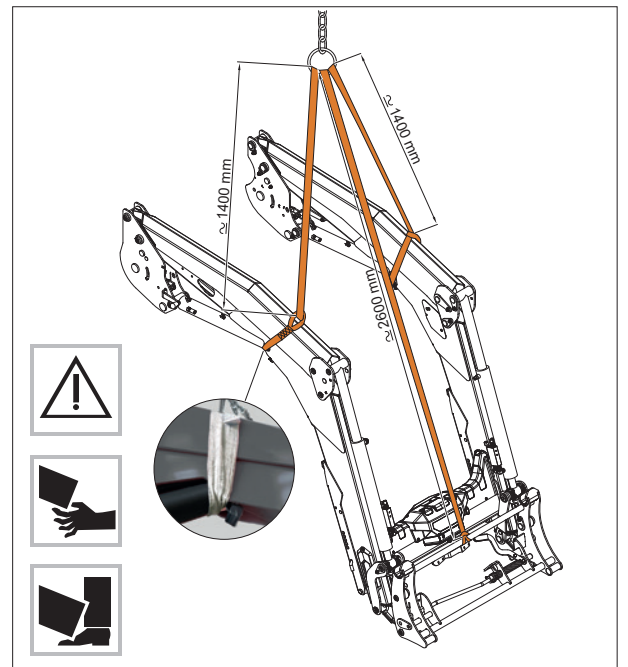

3. Loader preparation

3.1 T400 series, U500 series, A100 series loaders

3.1.1 Standard release handle kit (T400 and U500 series)

- Mount left and right release handles.

IMPORTANT: Check that the safety latches are in the hitching position (locking indicators in the red zone).

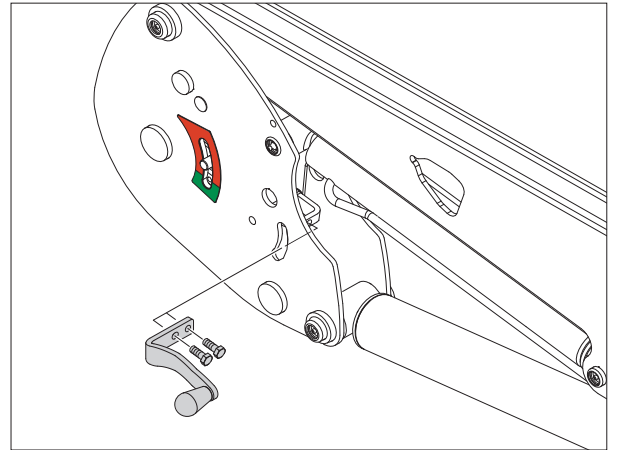

3.1.2 Standard release handle kit (A100 series)

- Mount left and right release handles.

IMPORTANT: Check that the safety latches are in the hitching position (locking indicators in the red zone).

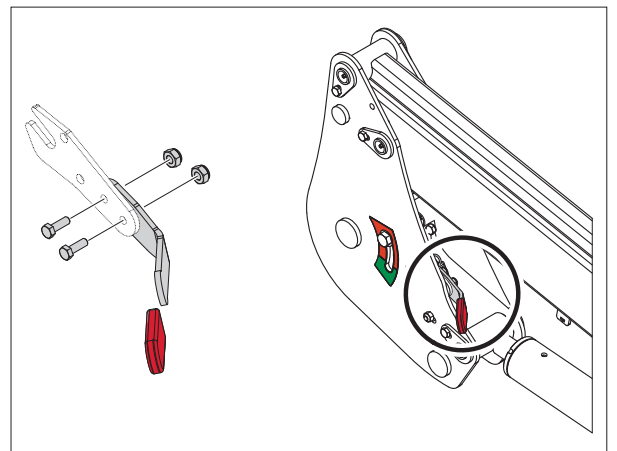

3.1.3 Installing the hose guide (T400evo, U500 series)

- Put the hoses down flat (1).
- Position the flange on the hoses 200 mm from the boom (2).
- Place the housing over the hitch frame (3).
- Fit the flange pin in its location (4).
- Position the screw (5) on the boom and screw on the lock nut (6).



3.1.4 Bracket preparation

- Remove paint as shown opposite.

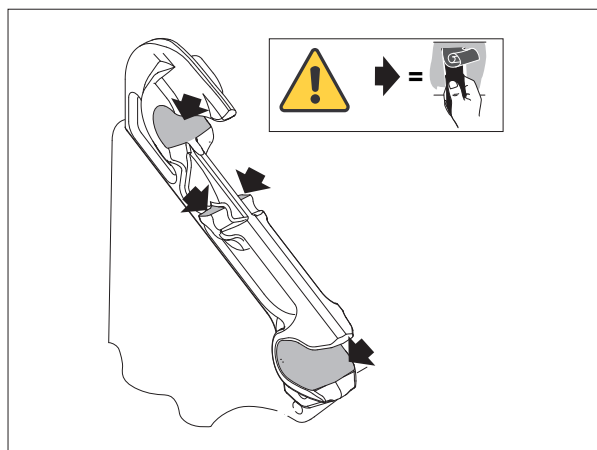

3.1.5 Mounting the roller kit (depending on the bracket model)

- T400 and U500 series loaders
Mount the rollers on the interior faces of the bracket arms (except special cases as detailed in the bracket mounting instructions).

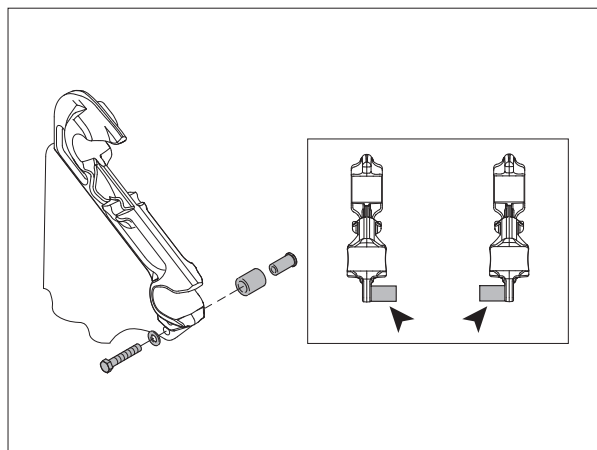

- A100 series loaders
Mount the rollers on the outer faces of the bracket arms.

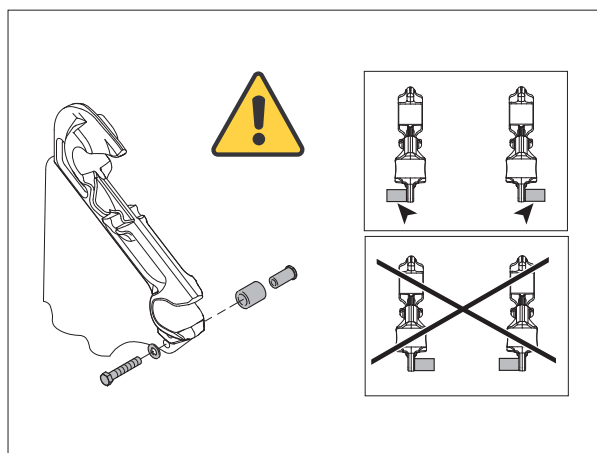

3.1.6 TX400, F300 series and COMPACT loaders

- Operate the pins in their housings before the first attachment is made.
- Remove paint as shown opposite.

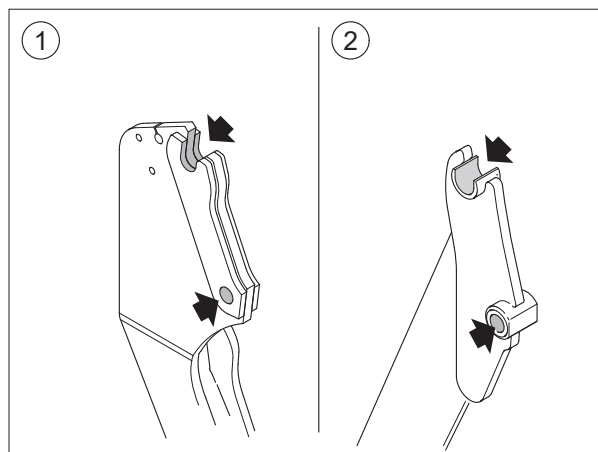

(1) TX400.
(2) F300, COMPACT.

4. Loader hitching

! This operation must be carried out by the driver, who must exit the cab and ensure all manoeuvres are prohibited while working on the loader.
Watch the unhitching/hitching video at www.m-x.eu

4.1 Pre-hitching checks

Check that there is enough clearance between the front mudguards and the hitching frames to avoid any unwanted catching.

If there is insufficient clearance, adjust the front mudguards accordingly. (See instructions for mounting the bracket).

4.2 T400 series, U500 series, A100 series loaders

4.2.1 Check on left/right frames

Check that the locking indicators on the left and right frames are in the red zone, and that there is nothing that may hamper the loader connection.



4.2.2 Loader hitching (except U500 series)

Attach the loader using lifting equipment (travelling gantry, crane) and guide the frames onto the bracket.

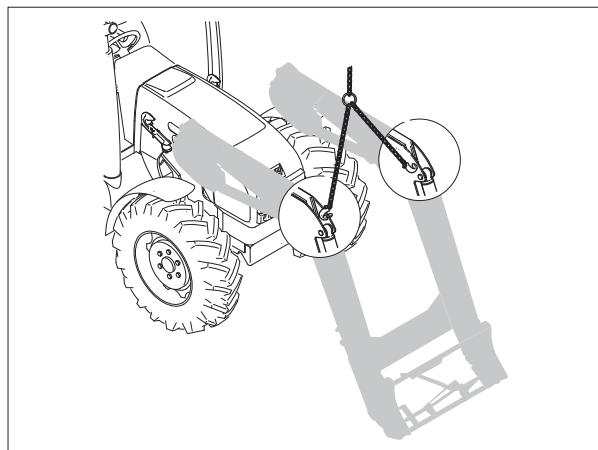

4.2.3 Loader hitching (U500 series)

Attach the loader using lifting equipment (travelling gantry, crane) and guide the frames onto the bracket.

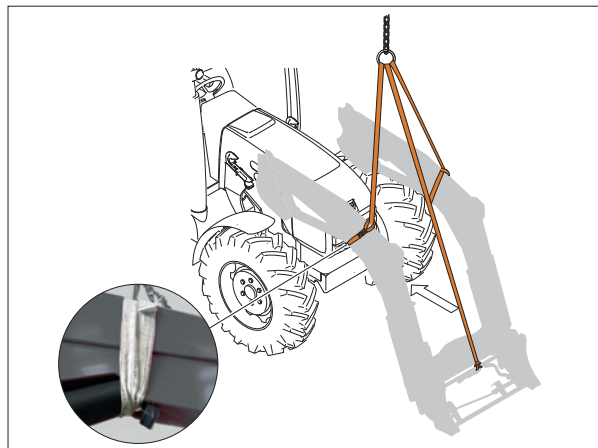

4.2.4 Locking and hitching the loader

— T400 series, U500 series loaders:

Check that the pins are engaged in the bracket heads. The indicators are in the green zone (automatic engagement of the safety latches).

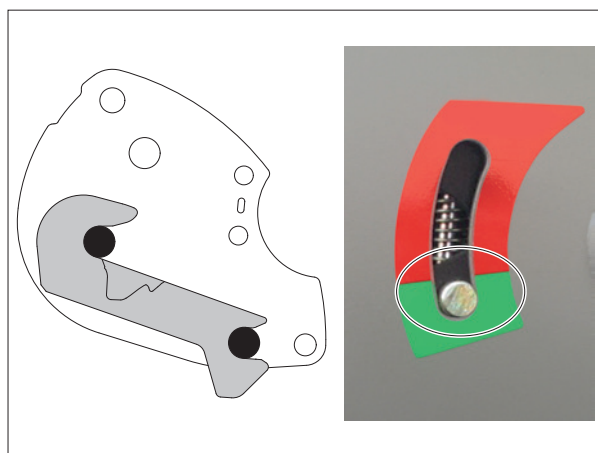

— A100 series loaders:

When the pins are engaged into the bracket heads, push the locking levers upwards. The indicators are in the green zone. (manual engagement of safety latches).

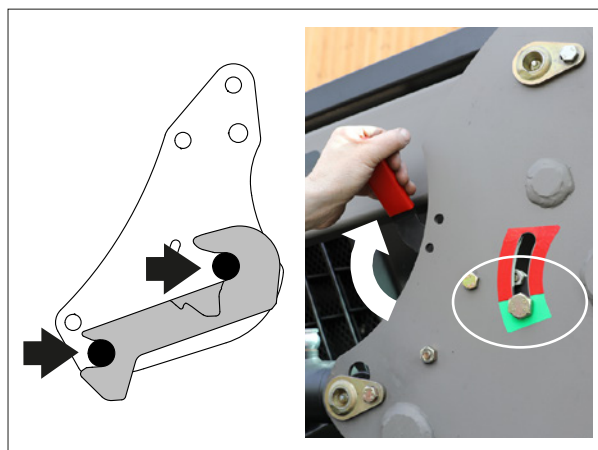

4.2.5 When the loader is hitched, the release levers should be in the position shown opposite.

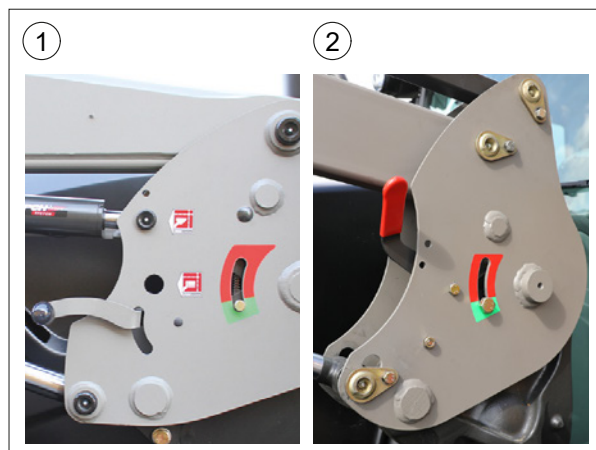

(1) T400, U500.
(2) A100.

4.3 TX400, F300 series and COMPACT loaders

Use a hoist for hitching. The lift rams must be fully retracted.
Engage the half-frame rounds in the bracket yokes.
Couple all the hydraulic functions together based on the colours of the couplers, then open the valve (if fitted) of the loader's lifting hydraulic circuit.
Operate the lift rams so that the locking pins can be engaged and the safety pins can be fitted.

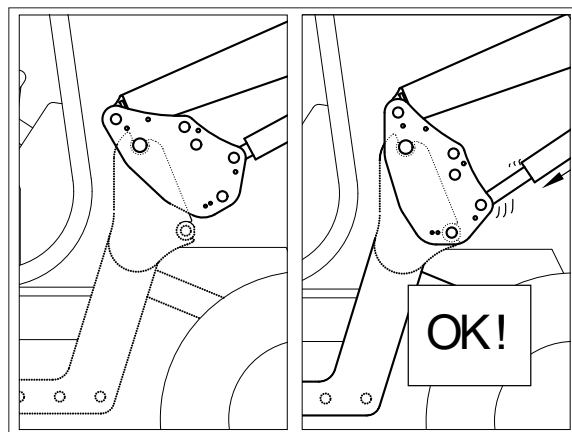

4.4 Final checks

Raise the front axle of the tractor and check, with maximum clearance (oscillation and maximum steering angle), that no part of the frame and the loader can come into contact with the tyres, mudguards and their housing, or any other part of the tractor.

5. Putting the loader into operation

Connecting the hydraulic lines. Slow pressurisation of the hydraulic unit.

Fully actuate each function several times to evacuate as much air as possible from the circuits.

- Lifting
- Dumping
- 3rd function
- 4th function
- Auxiliary functions (Fast-Lock, etc.)

IMPORTANT: Make sure that the entire hydraulic circuit is leak-free.
Repeat the hydraulic tests at maximum flow rate.

6. Implement hitching

! This operation must be carried out by the driver, who must exit the cab and ensure all manoeuvres are prohibited while working on the loader.

After hitching an implement to the loader (See “Implement hitching” in the user manual), lower the implement to the ground and visually check the position of the locks.



7. Washing

When using a pressure washer, do not stand too close to the loader and do not spray directly onto electrical components, linings, filler apertures, stickers, etc.

8. Tightening torque:

Check the tightness of the bracket after 10 and 50 hours' work, then every 100 hours or when the tractor's engine oil is changed (without bracket). If loose, please contact your dealer.

IMPORTANT: Before use, check that all screws/fasteners have the correct tightening torque.

Any screws that need to be retightened should be inspected, replaced if necessary, cleaned and reassembled using thread locking compound.

Tighten the screws at the tightening torque specified in the table below.

(Do not use an air gun to screw or tighten the screws/fasteners on the tractor).

8.1 Bracket maintenance specifications

Screwed linkage	Inspection schedule			Interval
	Indication on tractor hour meter			
	100h or first overhaul of new tractor *	600h or second tractor overhaul *	3000h	
Check that bolts between the tractor and our supply and among our parts are tightened to the recommended torque.	X	X		Then every 600h
Check that stem bolts are tightened to the recommended torque.	X		X	Then every 3000 hours

*depending on which is the first to happen.

! WARNING: To avoid any risk of serious or fatal accidents:

- Regularly check that the nuts and screws are properly tightened; refer to the checking table below.
- All screws requiring retightening must be inspected and, if necessary, replaced.
- Impact wrenches must not be used to screw or tighten the fasteners used on the tractor or on the parts of our supplied product.

— Tightening torques (Nm)

Class of bolt	Dowel marking (ISO 898)	Thread											
		M 5	M 6	M 8	M 10	M 12	M 14	M 16	M 18	M 20	M 22	M 24	M 27
8.8	○	5.2	9	21.6	43	73	117	180	259	363	495	625	915
10.9	□	7.6	13.2	31.8	63	108	172	264	369	517	704*	890	1304
12.9	△	8.9	15.4	37.2	73	126	201	309	432	605	824	1041	1526

* Unless otherwise specified.

Tightening torque for cast iron and steel (Nm) $\pm 15\%$.



M-extend France SAS
19, rue de Rennes
B.P. 83221
FR-35690 ACIGNÉ
Email : contact@m-x.eu
Web : www.m-x.eu