



SHEAR-GRAB

USER MANUAL

Dear user,

Thank you for choosing MX products. We hope you are fully satisfied with the implement you have purchased.

Take time out to read this manual to get the best possible results from your MX implement, to prolong its service life and to use it safely.

Your implement user manual is an important document. Keep it in a safe place, along with the assembly and hitching instructions supplied by your dealer, so you can easily consult them when necessary. These documents should be made available to any other users and provided to any new owner in the event that you sell your implement at a later date.

The illustrations and technical data provided in this document may not exactly correspond to your own implement. However, the user conditions remain the same.



WARNING: The implement should be handed over to the user by the dealer.

The demonstration of the equipment to be delivered should include:

- The safety rules related to the use of work implements.
- The principles of adjusting and adapting the implement may differ to suit the task at hand.



WARNING: If any of these requirements are omitted, please contact your dealer immediately.

The original French manuals are available [on the MX website](#).

MX is a trademark of M-extend France SAS, SIREN 639 200 260, RCS Rennes, 19 Rue de Rennes, BP 83 221 - 35 690 Acigné, France.



CAUTION: The operator must read this manual before using the loader for the first time.



- Any use that is not intended by the manufacturer is considered improper use and therefore constitutes misuse. The manufacturer cannot be held liable for any resulting damage.
- The safety information given in this manual does not replace safety codes, insurance requirements, local, state, or federal laws.

CONTENTS

1. Safety rules	6
1.1. Safety warning pictogram.....	7
1.2. PPE Table (Personal Protective Equipment).....	8
1.3. Hazardous areas around the tractor and front loader.....	8
1.4. Loader usage limits on a tractor without a cab or without a 4-post rollcage.....	9
1.5. Non-compliance with safety and use rules.....	10
2. Safety stickers	12
3. Identification plate	13
4. Description	14
4.1. General features.....	14
4.2. Hydraulic system.....	14
5. Counterweight	16
6. Operation	17
6.1. Rules of use.....	17
6.2. Silage cutting.....	17
6.3. Using the silage cutter implement.....	18
7. Hitching and unhitching the implement	21
8. Maintenance	22
8.1. Storage.....	24
8.2. Troubleshooting.....	24
9. Recycling MX products	25
10. Technical specifications	26



1. Safety rules

- Fit the tractor with a counterweight at the rear to balance the extra weight at the front.
- Never stand or walk under the load.
- Keep people away from the implement working area.
- Take extra care when anyone passes close to protruding components.
- Any work on the implement must be carried out by the driver, who should leave their seat and prevent any other operations being carried out while working on the implement.
- Please refer to the loader operator's user manual for hitching and unhitching the implement.
- The implement should be cleaned after each use. Lubricate the implement every 10 working hours and after each wash.
- The PPE (Personal Protective Equipment) listed in the [PPE Table](#) must be worn when operating this machinery.
- Seat belts must be worn by the driver and passengers.
- Before each use, the operator must check that the loader is correctly hitched and that the implement is correctly locked (test by pressing hard to the ground).
- Only control the loader from the cab. Ensure you remain in full control until all movement has finished.
- The controls must be locked when driving on the road (see controls user manual).
- When approaching a junction, release the controls then raise the loader to at least 2 m above the ground to avoid endangering other road users. After passing the junction, return the loader to its initial position and lock the controls again.
- When driving on the road, do not conceal the tractor's side lights and indicators.
- Do not leave the cab without stopping all control movements (control lever locked).
- Never leave the tractor unattended with the loader in the raised position. After using the loader, park the tractor with the loader lowered to the ground.
- All persons must be kept away from the area in which the loader is moving while it is in operation. If lifting operations require the presence of someone in close proximity to the load, the MX loader must be fitted with a safety device. For more information, please refer to the "Safety when Lifting and Dumping" chapter in the loader user manual.
- Before use, the operator should ensure that the loader-tractor unit and the implement-loader unit are compatible. Advice can be obtained from the current MX price list, available from your dealer.
- Operators should only use implements designed and recommended by the manufacturer for the job at hand.
- Never lift the loader and/or implement if the implement is obstructed/restricted in any way.
- The maximum permissible working speed is 5 km/h.
- Carrying or lifting persons using the loader is forbidden.
- Restrict all movements with the load lifted. The tractor may become unbalanced.
- The maximum front-axle load specified by the tractor manufacturer must not be exceeded.
- In order to limit stresses on the front axle and steering ram, and to limit tyre wear, move forwards or backwards when steering.
- The maximum load on the front tyres specified by the tyre manufacturer must not be exceeded.
- Check tyre pressure regularly.







- Periodically check that the safety pins and bolts are in place. Do not replace these with any other items such as nails, wires, etc.
- The tractor should at the very least be fitted with a roll-over protective structure (ROPS), which should be in the active position when using the loader.
- To use the MX loader safely, the tractor must be fitted with a cab protection structure or 4-post roll cage to protect against falling objects. Caution: the protective fitting must be in operational position during work. If the tractor is only fitted with a 2-post front or back roll cage, please see [Loader usage limits on a tractor without cab or without 4-post roll cage](#) and Operator Protective Guard OPG.
- Watch out for overhead electricity and telephone lines, guttering, framework, etc. when moving with the loader in its raised position.
- In compliance with standard EN 12525 + A2 2010, the controls for operating the loader and implements must be of the "sustained action" type, except for the floating position for lifting and/or dumping, which can be held in place by a notching system.
- Any fault diagnosis and/or removal of parts must be carried out by a professional who is to start by ensuring that the work will be carried out safely, with minimal risk to themselves and their environment, especially in the case of work on a lifted loader.
- For all operations on the machine, the risks of crushing or pinching must be managed, especially with moving parts.
- For all operations at height using the machine, equipment must be stable and secured. Stop the tractor engine if the loader is hitched to the tractor.
- Keep the tractor-loader unit clean to avoid the risk of fire. Check that airborne particles (straw, grass, wood shavings, etc.) do not accumulate in areas which reach high temperatures. Inspect and clean areas where various materials can accumulate, especially around the engine and the exhaust area.
- Check that the tractor is safely stopped after use.
- Before activating the decompression function, ensure that the implement is not loaded and, depending on the model, that its accessories are not active.
- Any work carried out on the implement must be done with the implement unloaded and, depending on the model, with its accessories at rest.
- When handling bales, check that the bale is held correctly before lifting the loader.

1.1. Safety warning pictogram

This safety pictogram is used throughout the manual to draw attention to the risk of material damage, injury or death. If this symbol is shown, read the warning message carefully. You must be familiar with the instructions and safety regulations before mounting or using the loader.

Pictogram	Term	Description
	DANGER	Indicates an imminently hazardous situation which, if not avoided, could result in death or serious injury.
	WARNING	Indicates a potentially hazardous situation which, if not avoided, could result in death or serious injury.
	CAUTION	Indicates a potentially hazardous situation which, if not avoided, could result in minor or moderate injury.
	IMPORTANT	Indicates a situation that could result in damage to equipment or property if instructions are not followed correctly.
	NOTE	Provides useful information.

1.2. PPE Table (Personal Protective Equipment)

Symbol	Meaning	Example of risk
	Protective gloves must be worn.	Cuts, trapped fingers, when unlocking the implement on the loader.
	Hearing protection must be worn.	Bucket shaking in a tractor without a cab.
	Eye protection must be worn.	Splashes during high-pressure cleaning.
	Safety helmets must be worn.	Impacts to the head from the loader during tractor maintenance.
	Protective clothing must be worn.	Splashes during high-pressure cleaning.
	Safety footwear must be worn.	Crushing when positioning parking stands.

1.3. Hazardous areas around the tractor and front loader

Using a front loader creates hazardous areas around the equipment, posing risks both to the operator and to people nearby. Clear identification of these areas is essential to ensure safety during handling, movement or ground-level operations.

③

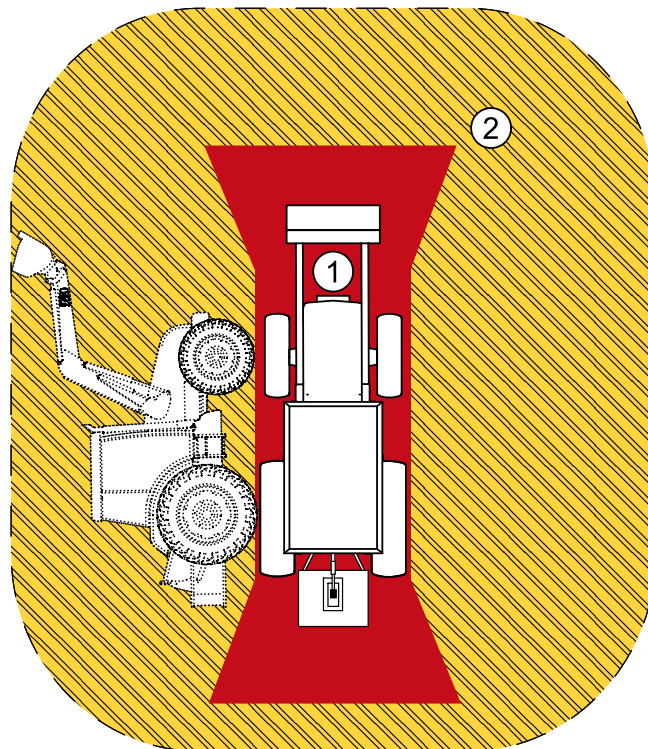

(1) Critical hazardous area (red) / (2) Peripheral hazardous area (striped orange) / (3) Working area

! **DANGER:** Keep hazardous areas clear and prohibit access to untrained persons. Constant vigilance is required.

Area	Description	Associated risks
(1) Critical hazardous area (red)	Immediate area around and under the tractor/loader unit.	Risk of serious injury or death in the event of the machine tipping, risk of mechanical crushing, reduced visibility for the operator, risk of entrapment in moving parts.
(2) Peripheral hazardous area (striped orange)	Area corresponding to the potential tipover area of the tractor fitted with a loader.	Risk of serious injury or death in the event of the machine tipping, risk of load falling on anyone within the area, reduced operator visibility.
(3) Working area (in relation to the type and layout of the farm)	Area encompassing all possible movements of the tractor and front loader during their operation.	Risk of collision, risk of crushing, limited operator field of view.

1.4. Loader usage limits on a tractor without a cab or without a 4-post rollcage

! **DANGER:** If the tractor is not fitted with a structure protecting against falling loads (cab or 4-post rollcage), the driver is exposed to constant risk when handling loads.

For safe work, the following safety precautions must be observed:

- Use the implement designed for the work to be carried out.
- Adjust the indicator rod in accordance with the implement being used.
- Ensure the stability and security of the load in the implement.
- The implement's maximum load level must not exceed the lowest side when handling bulk materials, and must not exceed the height of the backplate when handling unit loads [see Fig. 1].
- Move the tractor-loader unit smoothly.
- Travel with the load at ground level and at moderate speed.
- During lifting operations and when moving, ensure that you keep the load in sight, from the moment the implement pivot point (A) passes above the horizontal line of the loader pivot point (B) [see Fig. 2]. If necessary, correct the implement's position so that the load is never directed towards the driver [see Fig. 3].

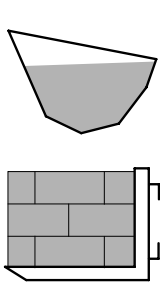

Fig. 1

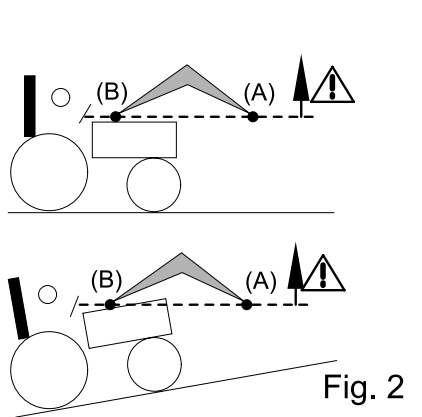

Fig. 2

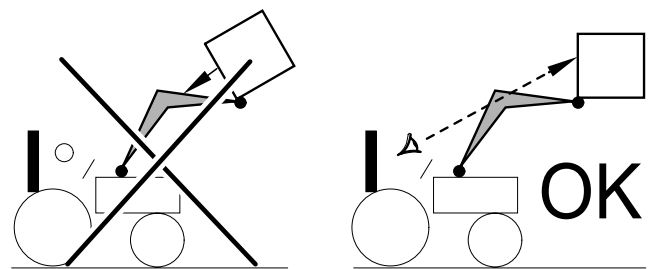

Fig. 3

! **DANGER:** If the load is not properly secured, the operator is exposed to the risk of the load falling when the implement pivot point (A) passes above the horizontal line of the loader pivot point (B) [see Fig. 2].

! **DANGER:** Do not crowd the loader when the implement pivot point (A) exceeds the horizontal line of the loader pivot point (B) [see Fig. 2].

1.5. Non-compliance with safety and use rules

- MX products are designed to be used at the maximum hydraulic pressure indicated by the manufacturer in the tractor's specifications. Use of higher pressure will result in additional stress and will invalidate the MX equipment warranty.
- Never modify the hose connections.
- Breaking the seals voids MX's liability for all items supplied.
- Any installation of an MX loader that does not comply with the recommendations set out in the MX price list in force on the date of purchase will void the MX warranty on all items supplied.
- Any modification to any item supplied by MX (implements, loader, frame, etc.), or installation or use of an implement or component not recommended by MX on the MX loader, will render the MX warranty on all supplied items null and void.
- Only use genuine MX spare parts. Do not carry out any modifications yourself or have anyone else do so on your MX loader and its implements (mechanical, electrical, hydraulic or pneumatic specifications) without obtaining MX's prior

written approval. Failure to comply with these rules may make your MX loader hazardous. In the event of damage or injury, MX will not be held liable in any way.

- Warranty cover will cease immediately in the event of failure to observe the standards and instructions for use and maintenance of the MX loader as stipulated in the user manual. MX may not be held liable for any accident resulting from actions contrary to these restrictions.

2. Safety stickers

Safety decals are affixed to implements. Ensure that these stickers are clean and legible; replace them if they become damaged. If a sticker needs replacing, clean the surface with isopropyl alcohol and affix the sticker using an appropriate tool.

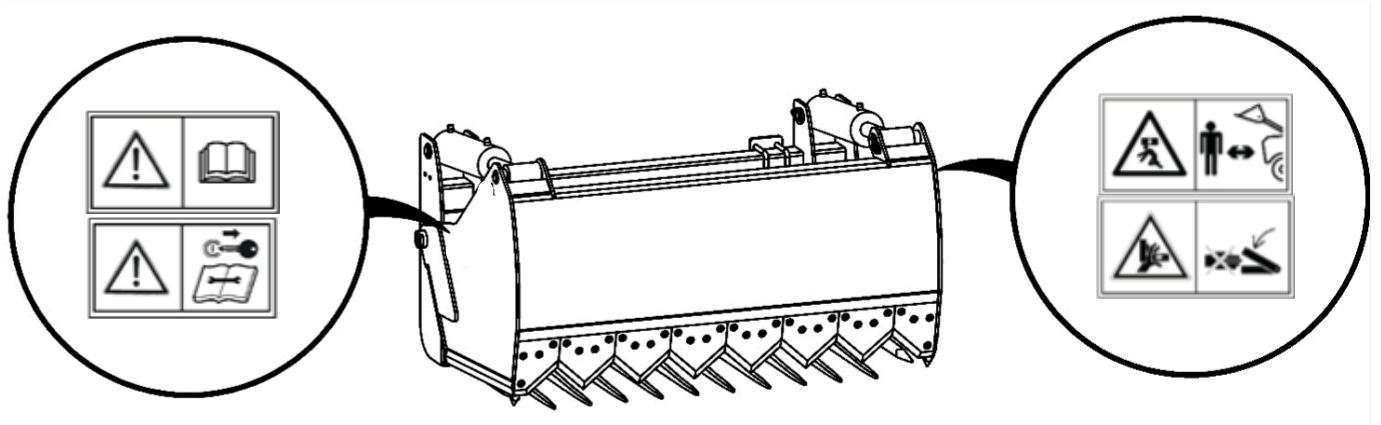

⚠ DANGER: Failure to follow these rules may result in serious injury or death.

Stickers present on the right side of the jaw

Symbol	Meaning
	Read the safety rules and operating instructions in the user manual before using the product.
	Switch off the engine and remove the keys from the ignition before carrying out maintenance or repairs.

Stickers present on the left side of the jaw

Symbol	Meaning
	Do not stand beneath the load.
	Do not put your hands in the crushing zone when the implement is in use, as there is a risk of crushing your hand or your fingers.

3. Identification plate

The identification plate is located on the right rear of the implement. The serial number and loader model shown on this plate must be quoted in any request for spare parts information or technical assistance.

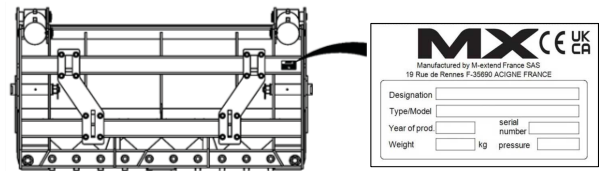

Marking	Description
(1)	Manufacturer's address
(2)	Product designation
(3)	Product type/model
(4)	Year of manufacture
(5)	Serial number
(6)	Product weight
(7)	Maximum Product Feed Pressure

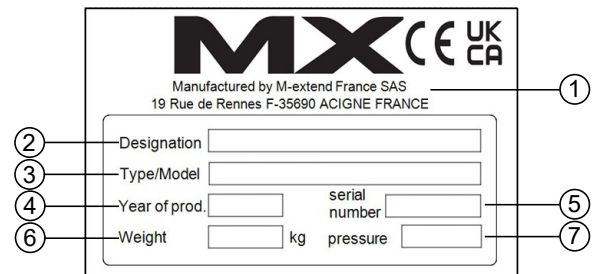

4. Description

4.1. General features

The silo cutter is fitted with a bolted hitch suitable for front loaders, in this example a EURO hitch.

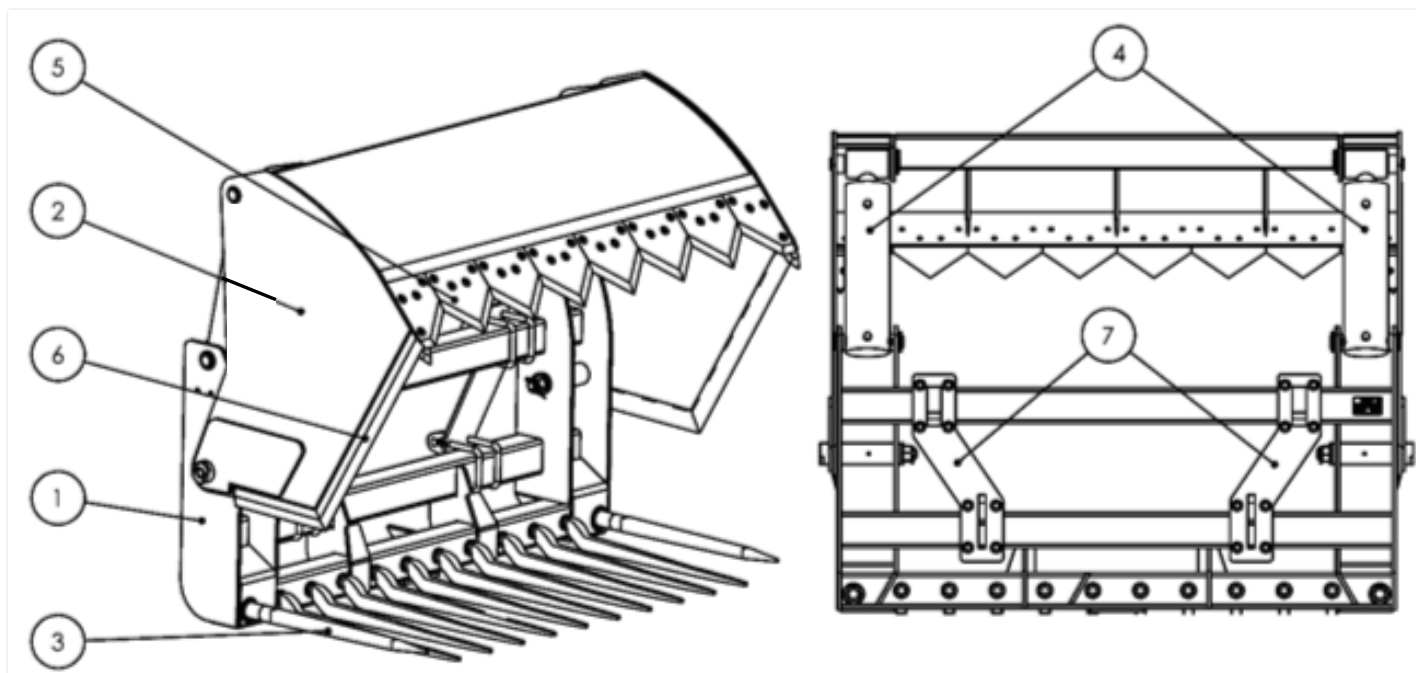

Marking	Description
(1)	Frame
(2)	Jaw piece
(3)	Tines
(4)	Rams
(5)	Front-mounted blades
(6)	Lateral blades
(7)	Hitching

4.2. Hydraulic system

The hydraulic system consists of two rams (three on the 200 version) and hydraulic hoses fitted with couplings that allow the jaw to move. The hydraulic system of the silo cutter is supplied with oil by the loader's hydraulic system.

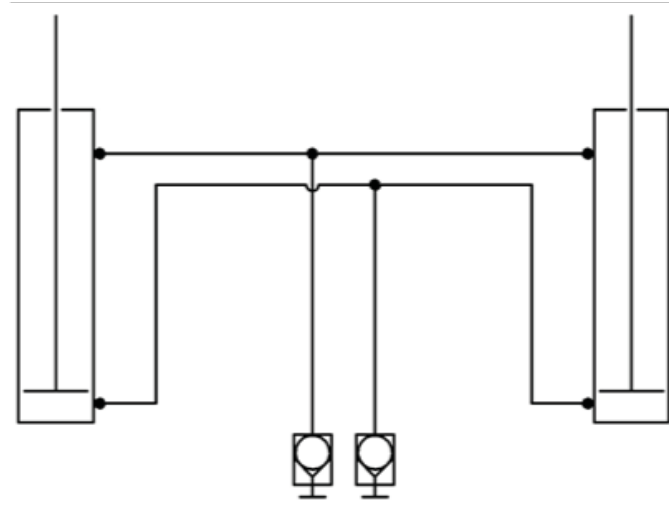

Hydraulics diagram for the shear grab

5. Counterweight

Tractor-loader unit stability can only be ensured with a counterweight installed on the rear of the tractor. This should ensure that 20% of the gross weight (tractor, loader, implement, maximum load and counterweight) remains on the rear axle of the tractor, for optimal working safety.

The formula includes the information shown below and is used to calculate the mass (M) of the counterweight (standard EN12525 + A2 2010).

$$M \geq \frac{5 N b + I2 (P + N - 5 G)}{5 (I1 + I2) - I2}$$

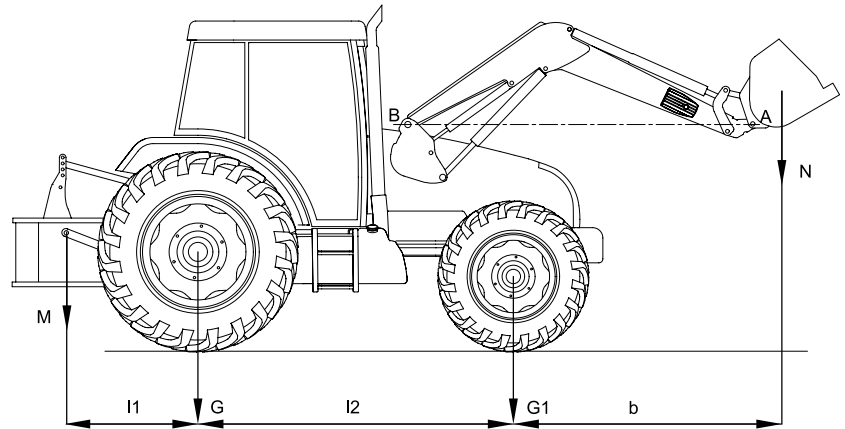

Letter	Correspondence
G	Load on rear axle, no counterweight, implement empty (kg)
G1	Load on front axle, no counterweight, implement empty (kg)
b	Distance from front axle to the implement's centre of gravity (mm)
I1	Distance from linkage arm pin to rear axle (mm)
I2	Wheelbase (mm)
N	Loader payload for implement pivot point (A), horizontally level with loader pivot point (B) (kg)
P	G + G1 (kg)
M	Counterweight (kg)

NOTE: the counterweight must not exceed the axle loads recommended by the manufacturer.

6. Operation

6.1. Rules of use

Each implement has been designed for a specific use and has its own strength limitations.

- Land clearing and stump removal are to be avoided. This work must be done with specialized machinery and is not appropriate for the agricultural loader.
- Use the tractor's driving power to penetrate into the material to be moved rather than speed, which subjects the loader and tractor to high stresses.
- Do not force the hydraulic components to work with excessively large loads. The same applies when the rams are fully extended. Release the spool valve control levers.
- Always work with a centred load.

Ensure that the implement is correctly locked in place before use.

Check the following:

- The hoses are properly connected and there are no leaks.
- The implement is working correctly (crowding/dumping/hydraulic function).
- The implement is correctly lubricated.
- There is no interference with the loader when at maximum crowding capacity.

6.2. Silage cutting

The silo cutter is designed to cut silage in silage storage silos. The following alternating cutting diagram should be used to ensure stable and trouble-free operation. This means that loads and pressures will be transmitted evenly to the various parts of the silo cutter.

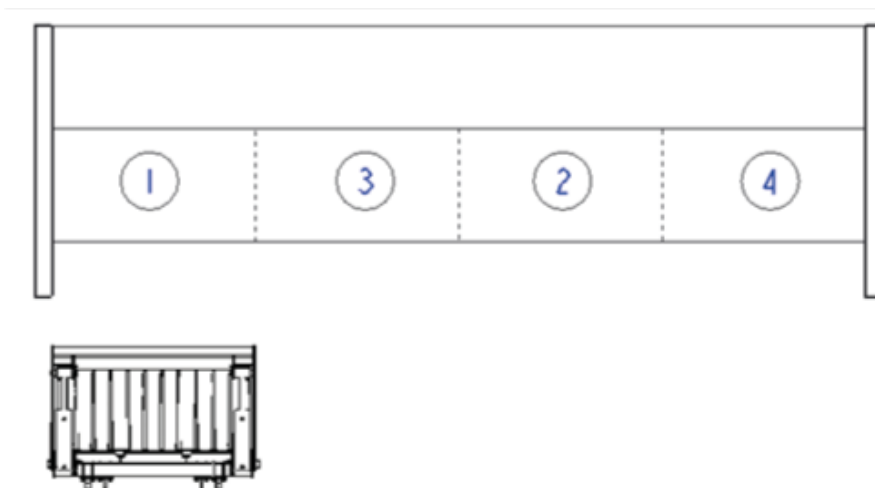



CAUTION: It is absolutely essential to avoid cutting with only one side of the silage cutter, as this can cause the jaw to get twisted and distorted.

6.3. Using the silage cutter implement

— Open the jaw and slowly approach the silage pile at the appropriate height.



— Move forwards to push the tines against the silage with downward pressure to prevent any unwanted raising of the implement.



— Close the jaw to cut the silage.



- Raise the silage cutter and slowly reverse the tractor in a straight line.



- Transport the silage to the unloading point with the silo cutter in the low and closed position.



- Raise the silo cutter to the required height, dump the silo cutter and open the jaw to empty it.



- Tilt the silo cutter slightly backwards to avoid potential collision with the container wall when moving backwards.



When cutting at the bottom of a silage silo stack, the silo cutter should be pointing slightly upwards.

The blades of the silo cutter jaw extend beyond the tines. When removing the silage with the jaw tines on the ground, there is a risk of the jaw teeth sinking into the ground. This prevents the silage from being fully cut and damages the silo cutter.

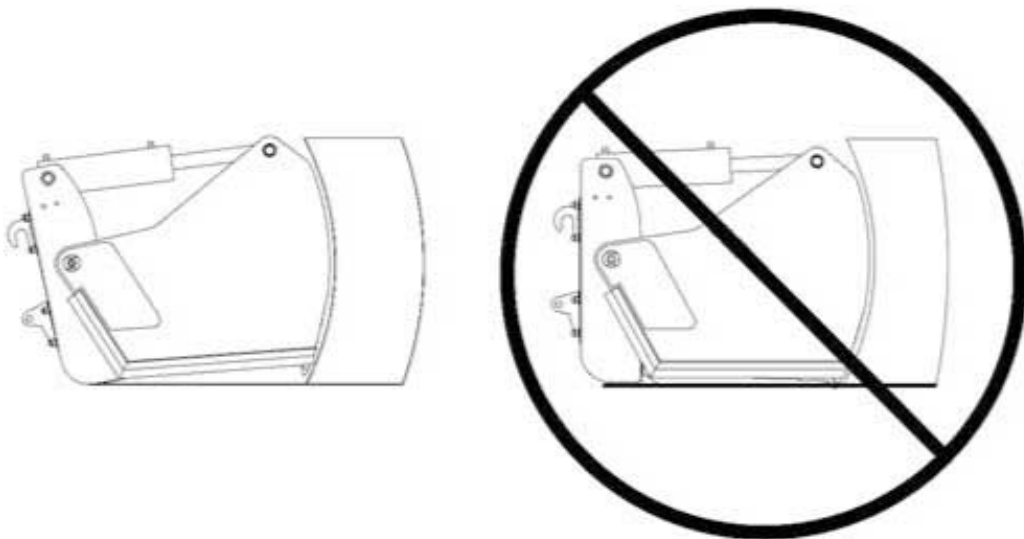

7. Hitching and unhitching the implement

⚠ WARNING: This operation must be carried out by the driver, who must leave the cab and not perform any manoeuvres while working on the loader.

Implements are designed for front loaders and telescopic handlers. Please refer to the relevant price list to identify suitable implements for loaders or telescopic handlers.

⚠ CAUTION: Never adapt or modify a hitch without prior approval from MX.

⚠ CAUTION: Hitching or unhitching the implement must always be performed with the implement in a lowered position (grab, jaw or rotor).

The implement is attached to the loader or telescopic handler using a hitch bolted with flanges.

- Always ensure that the implement carrier frame is compatible with the implement.
- Refer to the instructions for hitching and unhitching the implement in your loader or telescopic handler user manual.
- Make sure that the hitch shoes are centred on the implement when being assembled with the flanges.



Mechanically connect the implement and the loader or telescopic handler:

- For mechanical locking, refer to the loader's user manual or the telescopic handler hitching system documentation.
- Stop the loader or telescopic handler and reduce the pressure in the hydraulic circuit.
- Connect the implement and the loader or telescopic handler hydraulically and electrically (depending on configuration).

Note: For unhitching, position the implement on a flat, clean and stable surface.

8. Maintenance

 **WARNING:** Drain the tractor's hydraulic circuit regularly and change the filters in accordance with the manufacturer's recommendation.

Contaminated oil no longer lubricates and can cause damage to all hydraulic components (pumps, control valves, rams, etc.); even clear-looking oil may be worn out.

- Maintenance operations must be performed by competent people, authorised by the dealer. If not, these operations come under the sole responsibility of the person carrying out the work.
- It is mandatory to wear PPE (Personal Protective Equipment) for all maintenance operations. For more information, please refer to the PPE table, see [Safety rules](#).
- Switch off the tractor engine before carrying out any maintenance work on the loader and/or implements.
- For loader maintenance operations, never work on mechanical parts under stress, a pressurised hydraulic circuit or part, or an electrical circuit that is switched on.
- For tractor maintenance operations, it is strongly recommended that you unhitch the loader. Unhitching is a simple, quick operation that provides the best guarantees of safety and efficiency for tractor maintenance.
- For any work with the loader lifted, the loader must be locked in position:
 - Unlocking the MACH System for a loader with MACH System.
 - Closing the lifting rams supply valve for a loader without MACH System.

For more information, please refer to Unhitching the loader.

Grease every 10 hours and after each wash, especially after a high-pressure wash, as water drives out the grease. [See the lubricating points opposite.]

NOTE: NLGI 2 grease is recommended for maintenance.

Clean the implement and the front of the loader after each use. Slurry acid, fertiliser and silage can damage paint, steel and pivot points.

 **CAUTION:** When using a pressure washer, avoid spraying water on electric components.

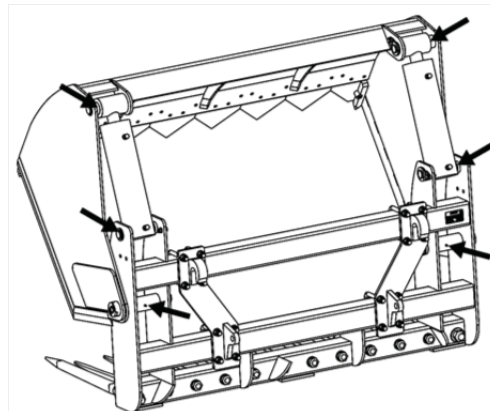

! **DANGER:** Oil escaping under pressure can have sufficient force to penetrate the skin and cause serious injury. Before disconnecting the hoses, ensure that you have released all the pressure. Before pressurising the system, check that all fittings are tight and that the hoses and hydraulic circuit are not damaged.

! **DANGER:** Oil escaping from a very small hole can be almost invisible. Use a piece of cardboard or wood, rather than your hands, to detect suspected leaks. If you are injured by a pressurised leak, seek immediate medical attention. An infection or serious reaction may develop if appropriate medical treatment is not immediately provided.

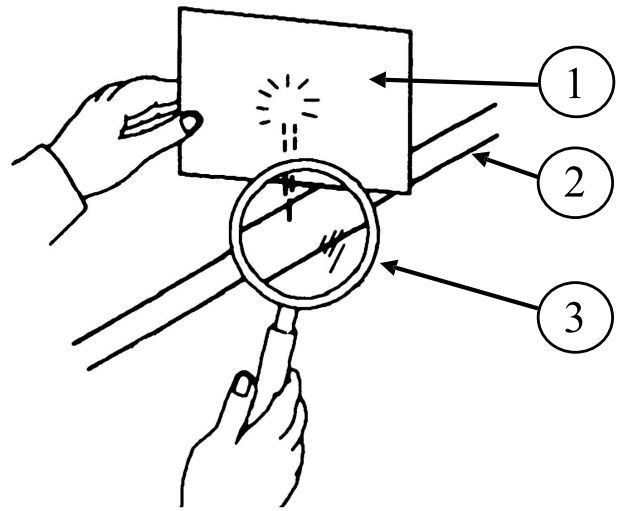

(1) Cardboard / (2) Hydraulic circuit / (3) Magnifying glass

Every month, or more often with heavy use, check:

- The condition of the loader and/or implement pivot points. As required, replace wear bushes and/or the pins.
- Wear bushes must be replaced if they are less than 1 mm thick.
- The tractor's hydraulic oil level and hydraulic circuit sealing. If you find any internal or external leaks on hydraulic components (rams, pipes, connectors, Mach, couplings, etc.), contact your dealer.
- Hose condition: replace them if any cracks or oil seepages appear.
- Correct operation of the monolever (cables, play, locking, etc.).
- Electric cabling condition. Contact your dealer if any connectors or cables become damaged.
- Mechanical condition (any cracks, warping, end stop matting, clearance, parking stands, etc.). Contact your dealer if there is any abnormal wear.

IMPORTANT: All fasteners/screws needing to be retightened must be inspected, replaced if necessary, cleaned and reassembled using locking compound (excluding brackets). Tighten the screws to the tightening torque recommended in the table below (Do not use an air gun to screw or tighten the screw/fasteners on the tractor).

Check the loader and implement tightness after 10 and 50 hours work, then every 100 hours or every time the tractor engine is drained. Contact your dealer if there is any loosening.

Tightening torque

Class of bolt	stud marking (ISO 898)	Thread											
		M5	M6	M7	M10	M12	M14	M16	M18	M20	M22	M24	M27
8.8	○	5.2	9	21.6	43	73	117	180	259	363	495	625	915
10.9	□	7.6	13.2	31.8	63	108	172	264	369	517	704*	890	1304
12.9	△	8.9	15.4	37.2	73	126	201	309	432	605	824	1041	1526

For cast steel (Nm) ±15%

* Unless otherwise specified

8.1. Storage

Store the implement in a flat, stable location.

 **CAUTION:** The implement should be stored with the grab completely closed.

 **CAUTION:** Do not unhitch the implement with the ram at the stop. Hydraulic overpressure can make it difficult to hitch the implement at a later date.

8.2. Troubleshooting

 **WARNING:** Maintenance operations must be performed by qualified people, authorised by the dealer. If this is not the case, the person carrying out the work will be fully liable for these operations.

Any fault diagnostics and/or removal of parts must be carried out by a professional who should start by ensuring that any work is carried out safely with minimal risk to themselves and their environment, especially in the case of work on a lifted loader.

It is strongly recommended to unhitch the loader to ensure safety and maintenance efficiency. For any maintenance operation on a loader and/or its implements:

- Switch off the tractor's engine.
- PPE must be worn.
- The loader must be on the ground with the implement and any accessories (grab, rotor, etc.) at rest.
- Decompress the hydraulic circuit.

Troubleshooting

Problem	Reason	Solution
The silo cutter does not open or close.	The hydraulic couplings are not connected properly.	Check connection and replace if necessary.
	The loader hydraulic system is faulty.	Perform diagnostics and repair the problem.
	The hoses are not connected properly.	Check connection and replace if necessary.
The silo cutter jaw dumps automatically.	The hydraulic lines or couplings are damaged.	Check the hydraulic lines and couplings. Replace if necessary.
	The hydraulic rams are damaged.	Check the hydraulic rams and replace if necessary
The jaw operates unevenly or has difficulty cutting.	The tractor oil level is too low.	Fill the tank to the recommended level.
	Air is present in the hydraulic system	Bleed the hydraulic system.
	The oil is contaminated.	Change the oil and filters.
	The blades are worn.	Sharpen the blades or contact the dealer to change them.

9. Recycling MX products

Disposal: please contact your dealer or a company specialising in materials recycling.

Hydraulic system

- End-of-life MX products must have their hydraulic oil drained by an authorised technician.
- The hydraulic hoses must be removed before the equipment can be recycled.
- All MX product owners are required to comply with these environmentally-friendly precautions if they decide to dismantle their end-of-life products themselves.

Disposal of hazardous waste (oils and hoses)

- Hydraulic oils must be stored in containers or drums provided for this purpose and sent to approved disposal facilities.
- For hydraulic hoses, the steel connectors can be separated from the rubber hoses.
- The steel end caps must be recycled as scrap by approved facilities.
- The rubber hoses must be placed in watertight containers and sent for processing by approved facilities.



High-tech MX product components and electrical and electronic equipment

- Waste electrical and electronic equipment (WEEE) present in MX products must be removed and disposed of by authorised services for recovery.

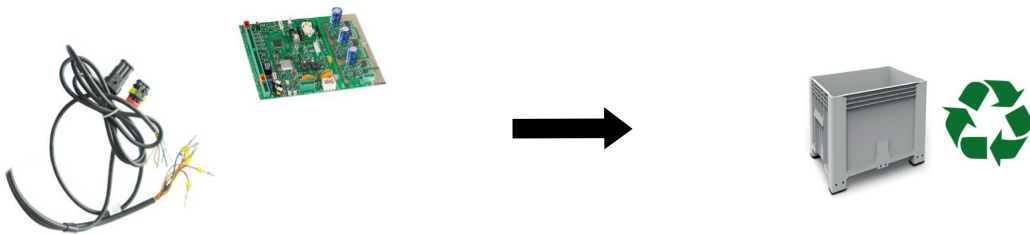

Recycling of decontaminated MX products

- Decontaminated MX products must be sent to authorised services for iron and metal recycling.

10. Technical specifications

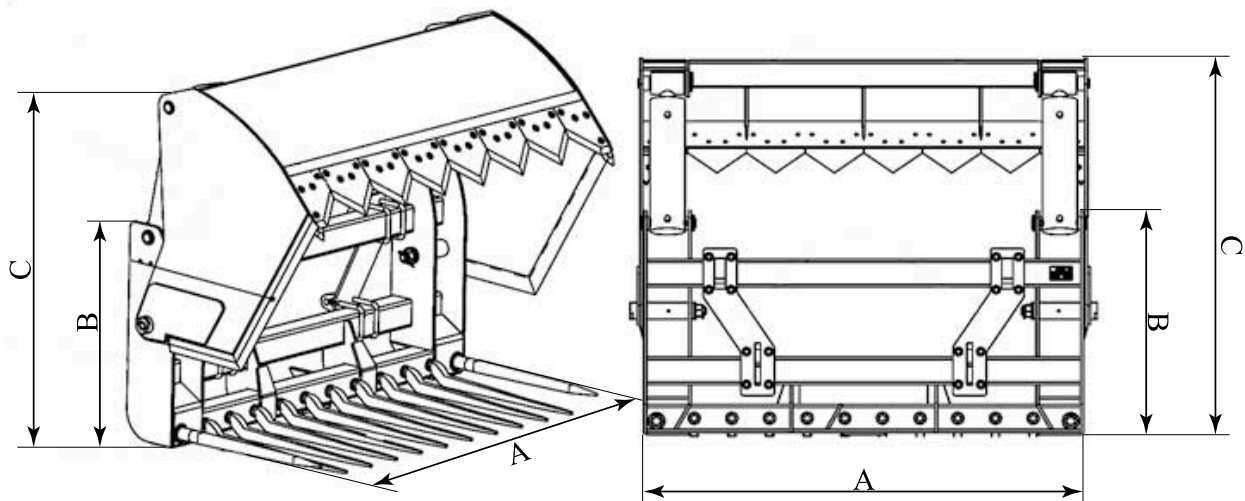

	SG 140	SG 160	SG 200
Dimensions			
Footprint (A)	1400 mm	1600 mm	2000 mm
Height (B)	850 mm	850 mm	850 mm
Height (C)	950 mm	950 mm	950 mm
Weight	470 kg	520 kg	670 kg
Number of tines	8+2	10+2	12+4
Number of rams	2	2	3

DECLARATION OF CONFORMITY



The manufacturer:

M-extend France SAS

Registered office: 19, Rue de Rennes, 35690 Acigné (France).

Registered with the RCS of Rennes under number 639 200 260.

Hereby declares that the material :

Front loader T408evo or T408+evo or T410evo or T410+evo or T412evo or T412+evo or T414evo or T417evo or T418evo or TX420 or TX425 or TX430

or

Front loader U503 or U504 or U505 or U506 or U506+ or U507 or U508 or U508+ or U509 or U510 or U510+ or U511 or U512 or U512+ or U514 or U514+

or

Front loader A104 or A106 or A110 or F303 or F304

or

Front loader C401 or C401XL or C402 or C402XL or C403 or C405 or C407 or C403 PRO or C404 PRO or C405 PRO or C406 PRO or C407 PRO or C408 PRO

or

Loader implement BMS or BRDS or BQU or BF + GF or CGU or TR or TRu or BMSC or CGC or TRC or BT or BR or BC or BF or BMSU or BRU or BFU or CL or BRC or BFC or LC or CG or BP or SG or BB or PCS or LS or PG

or

Implement for telescopic handler loader BMSA or CGA or BTA or TR or BCA or BCDA

or

Feeding bucket BD or GDT

or

Manubal L40 or L400 or L400HD or L500 or L6000 or C30 or C40 or U40 or V40 or V60 or V500 or W500 or V400HD or V5000HD or V7000HD

or

Front linkage R04 or R05 or R06 or R08 or R09 or R10 or R12 or R16 or R20 or R28 or R38

or

Weight M250 or M400 or MM600 or MM900 or MM1200 or MM1500 or MM400AD or MBX or MXS 250 or MXS 400 or MXS 600 or BOX 100L or BOX 150L or MBX XS

or

Multibumper

or

Safety Component OPG

serial number:

please write in the box above the serial number given on the equipment's nameplate.

**included in the list of serial numbers 000001001 to 999999365,
is in conformity with the Machinery Directive 2006/42/EC
and with the Supply of Machinery (Safety) Regulations 2008.**

M-extend France SAS, 19 rue de Rennes at Acigné (35690), is authorised to prepare the technical file.

Acigné, 13 October 2025.

B. Gauchenot
CEO



M-extend France : 19 rue de Rennes - 35690 ACIGNÉ

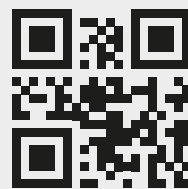

www.m-x.eu

© MX, part of M-extend